

RoHS Compliant Product

Description

The SE1085 is a low dropout at positive adjustable or fixed-mode regulator with min. of 3A output current capability. The product is specifically designed to provide well-regulated supply for low voltage IC applications such as high-speed bus termination and low current 3.3V logic supply. SE1085 is also well suited for other applications such as VGA cards. SE1085 is guaranteed to have lower than 1.4V dropout at full load current making it ideal to provide well regulated outputs of 1.25 to 5V with 4.7 to 12V input supply.

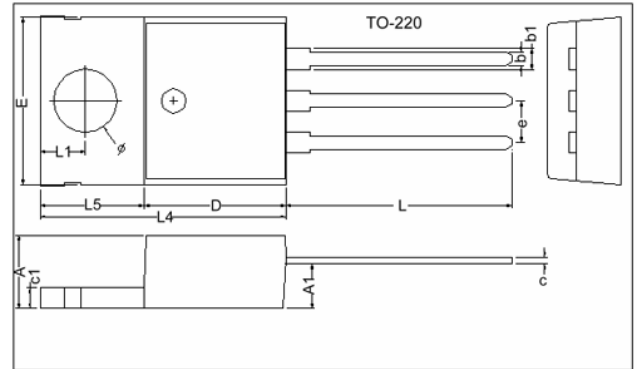

Features

- * 1.4V Max. Dropout Full Load Current
- * 3-Terminal Adjustable or Fixed 1.5V, 1.8V, 2.5V, 3.3V, 5.0V
- * Output Current Limiting
- * Fast Transient Response
- * Built-in Thermal Shutdown

REF.	Millimeter		REF.	Millimeter	
	Min.	Max.		Min.	Max.
A	4.40	4.80	c1	1.25	1.45
b	0.76	1.00	b1	1.17	1.47
c	0.36	0.50	L	13.25	14.25
D	8.60	9.00	e	2.54 REF.	
E	9.80	10.4	L1	2.60	2.89
L4	14.7	15.3	∅	3.71	3.96
L5	6.20	6.60	A1	2.60	2.80

Typical Circuit

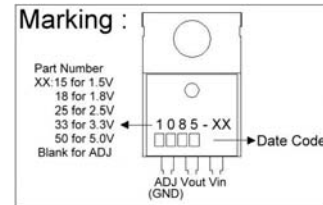
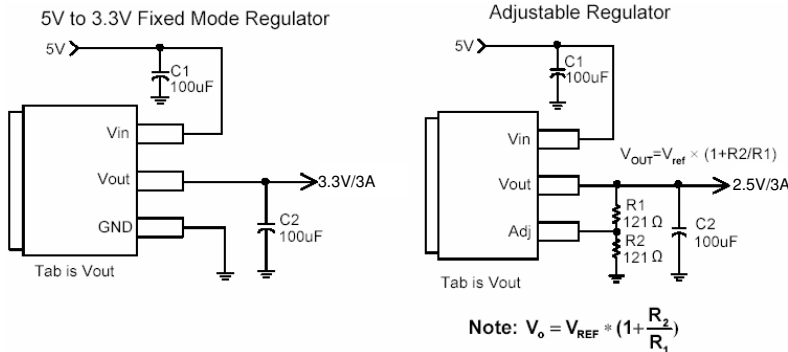

Block Diagram

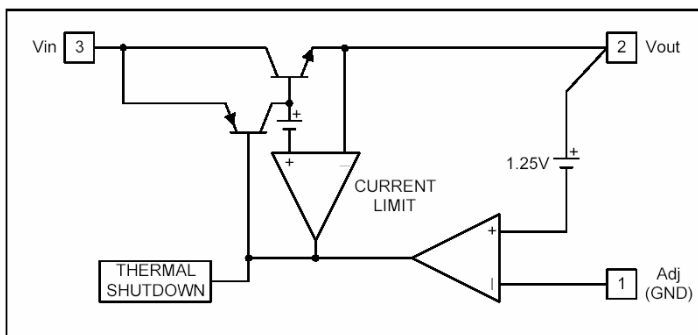

Pin Descriptions

Name	I/O	PIN#	FUNCTION
Adj (GND)		1	Adjustable (Ground only for fixed mode)
Vout	O	2	The output of the regulator. A minimum of 10uF capacitor must be connected from this pin to ground to insure stability.
Vin	I	3	The input pin of regulator .Typically a large storage capacitor is connected from this pin to ground to insure that the input voltage does not sag below the min. dropout voltage during the load transient response .This pin must always be 1.5V higher than Vout in order for the device to regulate properly.

Absolute Maximum Ratings

Parameter	Symbol	Ratings	Unit
DC Supply Voltage	V _{IN}	-0.3 to 12	V
Power Dissipation	P _D	Internally Limited	
Storage Temperature Range	T _{ST}	-65~+150	°C
Operating Junction Temperature Range	T _{OP}	0~+150	°C

Electrical Characteristics

Parameter	Conditions	MIN	TYP	MAX	UNIT
Reference Voltage	SE1085-ADJ I _o =10mA, T _J =25°C, (V _{in} -V _{out}) =1.5V	1.225	1.250	1.275	V
Output Voltage	SE1085-1.5 I _o =10mA, T _J =25°C, 3V≤V _{in} ≤12V	1.470	1.500	1.530	V
	SE1085-1.8 I _o =10mA, T _J =25°C, 3.3V≤V _{in} ≤ 12V	1.764	1.800	1.836	V
	SE1085-2.5 I _o =10mA, T _J =25°C, 4V≤V _{in} ≤12V	2.450	2.500	2.550	V
	SE1085-3.3 I _o =10mA, T _J =25°C, 4.8V≤V _{in} ≤ 12V	3.235	3.300	3.365	V
	SE1085-5.0 I _o =10mA, T _J =25°C, 6.5V≤V _{in} ≤ 12V	4.900	5.000	5.100	V
Line Regulator	SE1085-XXX I _o =10mA, V _{out} +1.5<V _{in} <12	-	-	0.2	%
Load Regulation	SE1085-ADJ V _{in} =3.3V, 0mA<I _o <3A, T _J =25°C (Note 1,2)	-	-	5	mV
	SE1085-1.5 V _{in} =3.0V, 0mA<I _o <3A, T _J =25°C (Note 1,2)	-	2	5	mV
	SE1085-1.8 V _{in} =3.3V, 0mA<I _o <3A, T _J =25°C (Note 1,2)	-	15	18	mV
	SE1085-2.5 V _{in} =4.0V, 0mA<I _o <3A, T _J =25°C (Note 1,2)	-	20	25	mV
	SE1085-3.3 V _{in} =5.0V, 0mA<I _o <3A, T _J =25°C (Note 1,2)	-	26	33	mV
	SE1085-5.0 V _{in} =8.0V, 0mA<I _o <3A, T _J =25°C (Note 1,2)	-	40	50	mV
Dropout Voltage (V _{in} -V _{out})	SE1085-XXX I _o =3A(ΔV _{out} =1% V _{out})	-	1.3	1.4	V
Current Limit	SE1085-XXX V _{in} -V _{out} =5V	3.1	-	-	A
Minimum Load Current	SE1085-XXX 0°C ≤ T _J ≤125°C	-	5	10	mA
Thermal Regulation	T _A =25°C, 30ms pulse	-	0.008	0.04	%/W
Ripple Rejection	F=120Hz, C _{OUT} =25uF, Tantalum, I _o =3A	-	-	-	-
	SE1085-XXX V _{in} =V _{out} +3V	-	60	70	dB
Temperature Stability	I _o =10mA	-	0.5	-	%
Thermal Resistance Junction-to-Ambient (No heat sink ;No air flow)		-	83	-	°C/W
Thermal Resistance Junction-to-Case	Control Circuitry/Power Transistor	-	0.65/2.7	-	°C/W

Note 1: See thermal regulation specifications for changes in output voltage due to heating effects. Line and load regulation are measured at a constant junction Temperature by low duty cycle pulse testing. Load regulation is measured at the output lead =1/18" from the package.

Note 2: Line and load regulation are guaranteed up to the maximum power dissipation of 15W. Power dissipation is determined by the difference in input and output and the output current. Guaranteed maximum power dissipation will not be available over the full input/output range.

Note 3: Quiescent current is defined as the minimum output current required in maintaining regulation. At 12V input/output differential the device is guaranteed to regulate if the output current is greater than 10mA.



Elektronische Bauelemente

SE1085

3A Low Dropout Positive
Adjustable or Fixed-Mode Regulator

Functional Description

Introduction

The SE1085 adjustable or fixed-mode Low Dropout (LDO) regulator is a 3 terminal device which can easily be programmed by internal mask change to any voltage within the range of 1.25 to $V_{in}-1.4V$. The SE1085 only needs 1.4V differential between V_{in} and V_{out} to maintain output regulation, in addition, the output voltage tolerances are also extremely tight and they include the transient response as part of the specification. For example, Intel VRE specification calls for a total of $\pm 100mV$ including initial tolerance, load regulation and 0 to 3A load step. The SE1085 is specifically designed to meet the fast current transient needs as well as providing an accurate initial voltage, reducing the overall system cost with the need for fewer output capacitors.

Load Regulation

Since the SE1085 is only a 3 terminal device, it is not possible to provide true remote sensing of the output voltage at the load. But it can supply good load regulation by internal feedback bypass the external loss such as adjustable mode.

Stability

The SE1085 requires the use of an output capacitor as part of the frequency compensation in order to make the regulator stable. For most applications a minimum of 10 μF aluminum electrolytic capacitor insures both stability and good transient response.

Thermal Design

The SE1085 incorporates an internal shutdown that protects the device when the junction temperature exceeds the maximum allowable junction temperatures. Although this device can operate with junction temperatures in the range of 150°C, it is recommended that the selected heat sink be chosen such that during maximum continuous load operation the junction temperature is kept below the temperature.

Layout Consideration

The output capacitors must be located as close to the V_{out} terminal of the device as possible. It is recommended to use a section of a layer of the PC board as a plane to connect the V_{out} pin to the output capacitors to prevent any high frequency oscillation that may result due to excessive trace inductance.

Performance Characteristics

