

RoHS Compliant Product
A suffix of "-C" specifies halogen & lead-free

DESCRIPTIONS

The device uses advanced trench technology to provide excellent $R_{DS(ON)}$, low gate charge and operation with gate voltage as low as 2.5V. This device is suitable for the use as a load switch or in PWM applications.

FEATURES

- High power and current handling capability
- Lead free product is available
- Surface mount package

APPLICATIONS

- PWM applications
- Load switch
- Power management

MARKING

2305

PACKAGE INFORMATION

Package	MPQ	Leader Size
SOT-23	3K	7 inch

ABSOLUTE MAXIMUM RATINGS ($T_A=25^\circ\text{C}$ unless otherwise specified)

Parameter		Symbol	Rating	Unit
Drain-Source Voltage		V_{DS}	-20	V
Continuous Gate-Source Voltage		V_{GS}	± 12	V
Continuous Drain Current	$T_C=25^\circ\text{C}$	I_D	-4.1	A
	$T_C=70^\circ\text{C}$		-3.2	
	$T_A=25^\circ\text{C}$		-3	
	$T_A=70^\circ\text{C}$		-2.3	
Pulsed Drain Current ¹		I_{DM}	-15	A
Maximum Power Dissipation		P_D	1.7	W
Thermal Resistance from Junction to Ambient ²		$R_{\theta JA}$	74	$^\circ\text{C} / \text{W}$
Junction and Storage Temperature Range		T_J, T_{STG}	-55~150	$^\circ\text{C}$

SOT-23

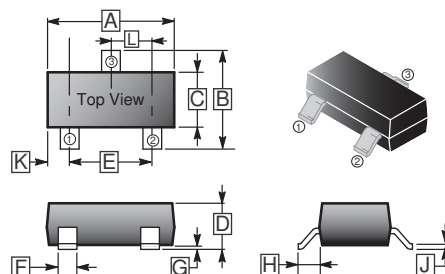

REF.	Millimeter		REF.	Millimeter	
	Min.	Max.		Min.	Max.
A	2.70	3.10	G	0.01	0.18
B	2.10	2.95	H	0.5 Typ.	
C	1.20	1.7	J	0.08	0.20
D	0.89	1.3	K	0.6 REF.	
E	1.70	2.3	L	0.95 BSC.	
F	0.30	0.50			

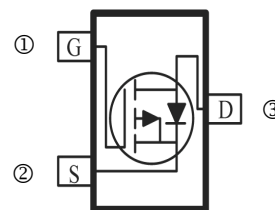

ELECTRICAL CHARACTERISTICS ($T_A=25^\circ\text{C}$ unless otherwise specified)

Parameter	Symbol	Min.	Typ.	Max.	Unit	Test Condition
Off Characteristics						
Drain-Source Breakdown Voltage	BV_{DSS}	-20	-	-	V	$V_{GS}=0, I_D = -250\mu\text{A}$
Zero Gate Voltage Drain Current	I_{DSS}	-	-	-1	μA	$V_{DS} = -20\text{V}, V_{GS}=0$
Gate-Source Leakage Current	I_{GSS}	-	-	± 100	nA	$V_{GS}=\pm 12\text{V}, V_{DS}=0$
On Characteristics ³						
Gate-Source Threshold Voltage	$V_{GS(th)}$	-0.45	-0.7	-1	V	$V_{DS}=V_{GS}, I_D = -250\mu\text{A}$
Static Drain-Source On Resistance	$R_{DS(ON)}$	-	39	52	m Ω	$V_{GS} = -4.5\text{V}, I_D = -4.1\text{A}$
		-	58	75		$V_{GS} = -2.5\text{V}, I_D = -3\text{A}$
Forward Transconductance	g_{FS}	6	-	-	S	$V_{DS} = -5\text{V}, I_D = -2\text{A}$
Dynamic Characteristics						
Input Capacitance	C_{iss}	-	740	-	pF	$V_{DS} = -4\text{V}$ $V_{GS}=0$ $f=1\text{MHz}$
Output Capacitance	C_{oss}	-	290	-		
Reverse Transfer Capacitance	C_{rss}	-	190	-		
Switching Characteristics						
Turn-On Delay Time	$T_{d(on)}$	-	12	-	nS	$V_{DD} = -4\text{V}$ $V_{GEN} = -4.5\text{V}$ $I_D = -3.3\text{A}$ $R_L = 1.2\Omega$ $R_G = 1\Omega$
Rise Time	T_r	-	35	-		
Turn-Off Delay Time	$T_{d(off)}$	-	30	-		
Fall Time	T_f	-	10	-		
Total Gate Charge	Q_g	-	7.8	-	nC	$V_{DS} = -4\text{V}$ $V_{GS} = -4.5\text{V}$ $I_D = -4.1\text{A}$
Gate-Source Charge	Q_{gs}	-	1.2	-		
Gate-Drain ("Miller") Charge	Q_{gd}	-	1.6	-		
Source-Drain Diode Characteristics						
Continuous Current ²	I_S	-	-	-1.6	A	
Forward Voltage ³	V_{SD}	-	-	-1.2	V	$I_S = -1.6\text{A}, V_{GS}=0$

Notes:

1. Repetitive Rating: Pulse width is limited by maximum junction temperature.
2. Surface mounted on a 1 inch² copper pad of a FR4 board and $t \leq 10\text{sec}$.
3. Pulse Test: Pulse width $\leq 300\mu\text{s}$, duty cycle $\leq 2\%$.

CHARACTERISTIC CURVE

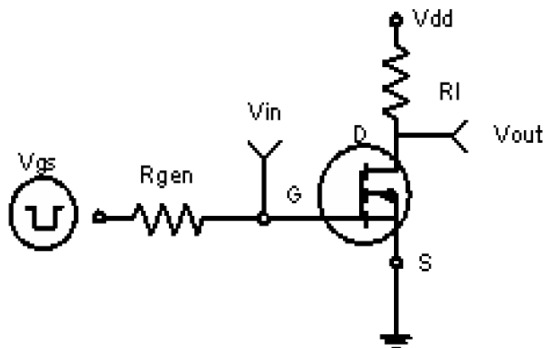

Figure 1: Switching Test Circuit

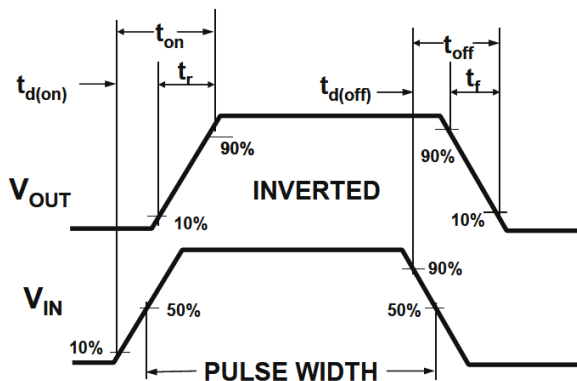

Figure 2: Switching Waveforms

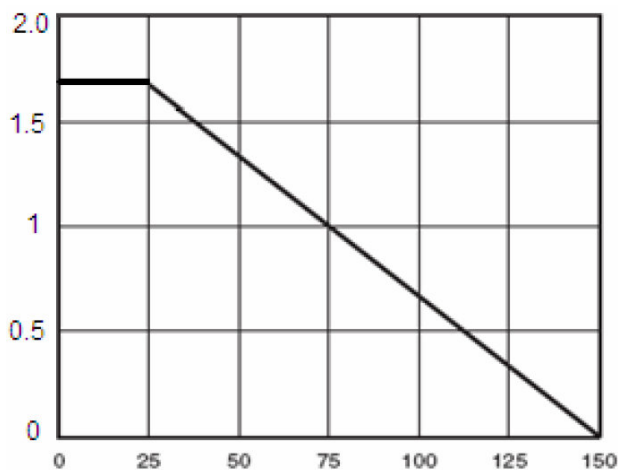

Figure 3 Power Dissipation

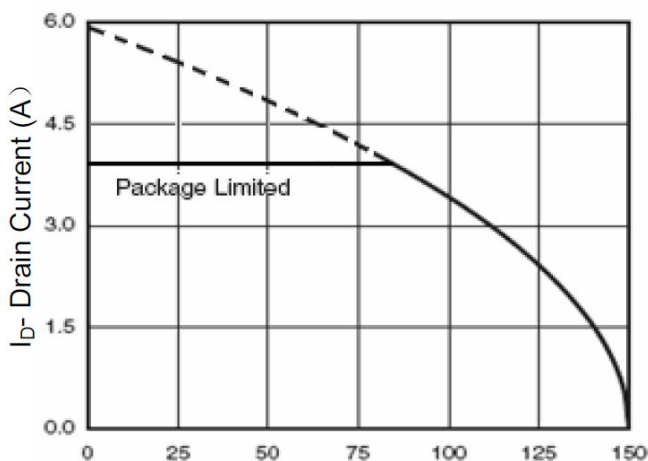

Figure 4 Drain Current

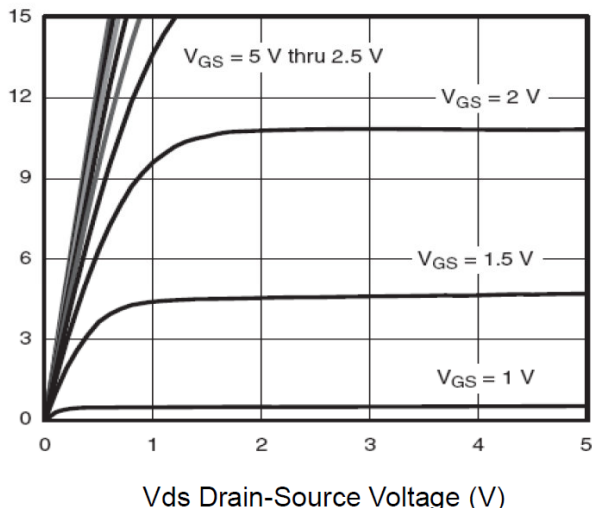

Figure 5 Output Characteristics

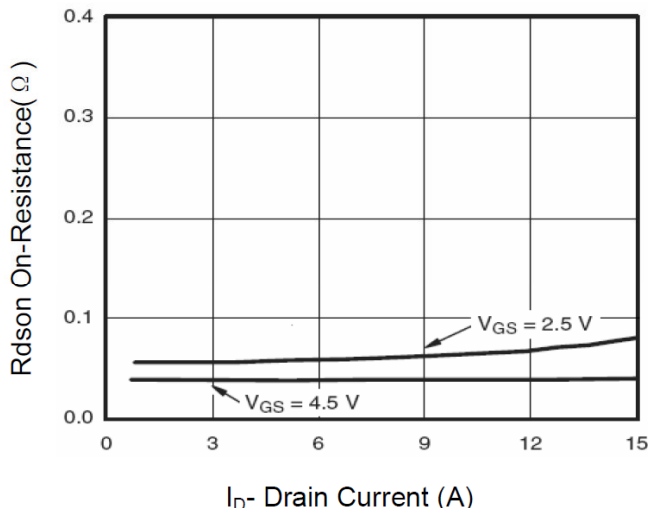
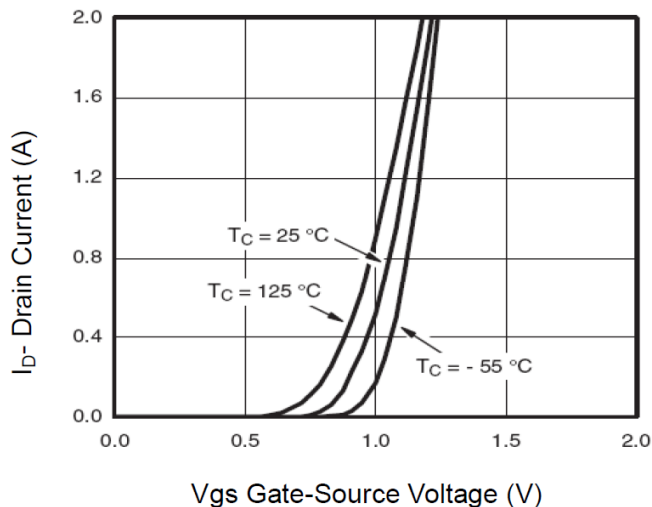
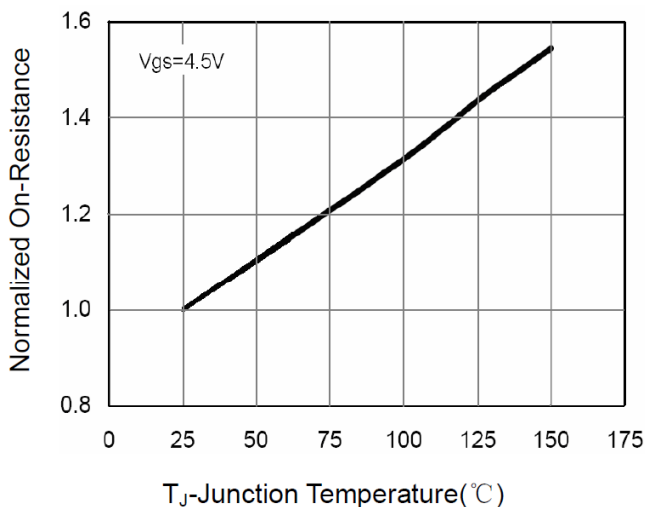

Figure 6 Drain-Source On-Resistance

CHARACTERISTIC CURVE



Vgs Gate-Source Voltage (V)
Figure 7 Transfer Characteristics



T_J -Junction Temperature ($^\circ\text{C}$)
Figure 8 Drain-Source On-Resistance

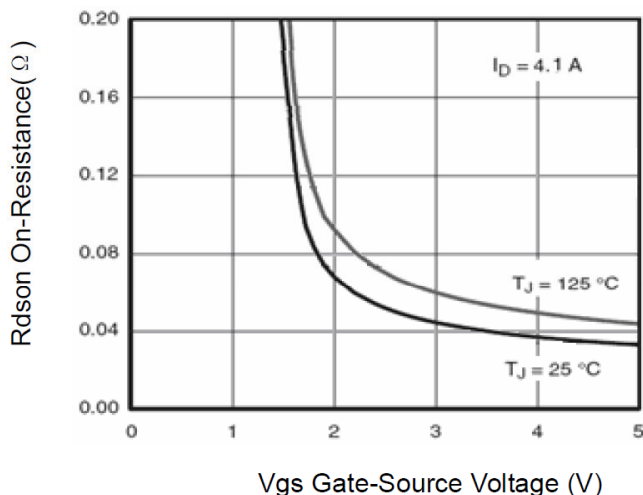

Vgs Gate-Source Voltage (V)
Figure 9 Rdson vs Vgs

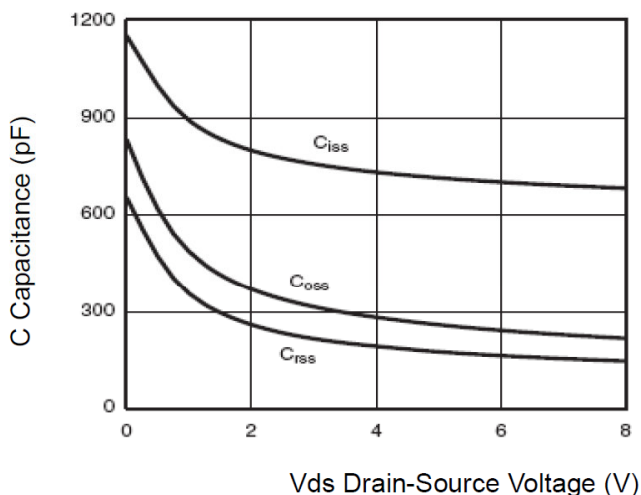

Vds Drain-Source Voltage (V)
Figure 10 Capacitance vs Vds

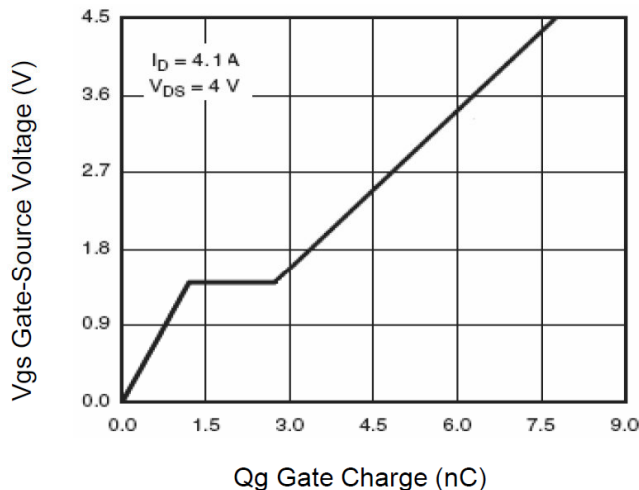

Qg Gate Charge (nC)
Figure 11 Gate Charge

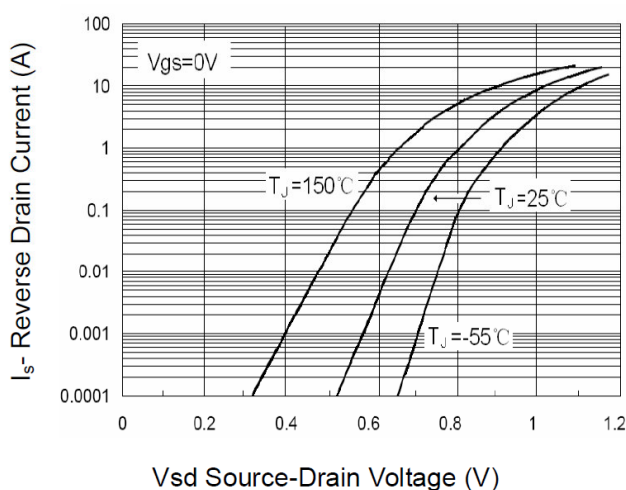

Vsd Source-Drain Voltage (V)
Figure 12 Source- Drain Diode Forward