

RoHS Compliant Product
A suffix of "-C" specifies halogen and lead-free

DESCRIPTION

These miniature surface mount MOSFETs utilize a high cell density trench process to provide low $R_{DS(on)}$ and to ensure minimal power loss and heat dissipation.

FEATURES

- Low $R_{DS(on)}$ provides higher efficiency and extends battery life
- Low thermal impedance copper leadframe SOT-363 saves board space
- Fast switching speed
- High performance trench technology

APPLICATION

DC-DC converters and power management in portable and battery-powered products such as computers, printers, PCMCIA cards, cellular and cordless telephones.

SOT-363

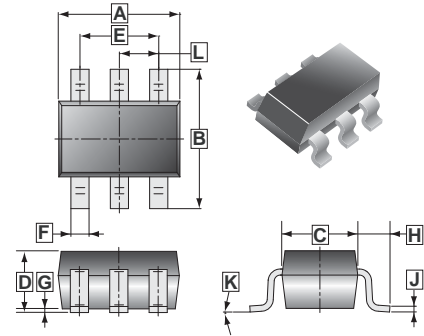

REF.	Millimeter		REF.	Millimeter	
	Min.	Max.		Min.	Max.
A	1.80	2.20	G	0.100	REF.
B	1.80	2.45	H	0.525	REF.
C	1.15	1.35	J	0.08	0.25
D	0.80	1.10	K	8°	
E	1.10	1.50	L	0.650 TYP.	
F	0.10	0.35			

MARKING

K1

PACKAGE INFORMATION

Package	MPQ	Leader Size
SOT-363	3K	7 inch

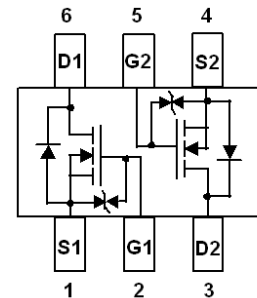

ABSOLUTE MAXIMUM RATINGS ($T_A=25^\circ\text{C}$ unless otherwise specified)

Parameter	Symbol	Ratings	Unit
Drain-Source Voltage	V_{DS}	30	V
Gate-Source Voltage	V_{GSS}	± 20	V
Continuous Drain Current ¹	I_D	0.1	A
Power Dissipation ¹	P_D	0.15	W
Maximum Junction to Ambient ¹	$R_{\theta JA}$	833	$^\circ\text{C} / \text{W}$
Operating Junction and Storage Temperature Range	T_J, T_{STG}	150, -55~150	$^\circ\text{C}$

ELECTRICAL CHARACTERISTICS ($T_A=25^\circ\text{C}$ unless otherwise specified)

Parameter	Symbol	Min.	Typ.	Max.	Unit	Teat Conditions
Static						
Drain-Source Breakdown Voltage	V_{DS}	30	-	-	V	$I_D=10\mu\text{A}$, $V_{GS}=0$
Zero Gate Voltage Drain Current	I_{DSS}	-	-	1	μA	$V_{DS}=30\text{V}$, $V_{GS}=0$
Gate-Source Leakage Current	I_{GSS}	-	-	± 1	μA	$V_{DS}=0$, $V_{GS}=\pm 20\text{V}$
Gate-Threshold Voltage	$V_{GS(th)}$	0.8	-	1.5	V	$V_{DS}=3\text{V}$, $I_D=100\mu\text{A}$
Drain-Source On-Resistance	$R_{DS(ON)}$	-	-	8	Ω	$V_{GS}=4\text{V}$, $I_D=10\text{mA}$
		-	-	13		$V_{GS}=2.5\text{V}$, $I_D=1\text{mA}$
Forward Transconductance	g_{fs}	20	-	-	S	$V_{DS}=3\text{V}$, $I_D=10\text{mA}$
Dynamic ¹						
Input Capacitance	C_{ISS}	-	13	-	nC	$V_{DS}=5\text{V}$, $V_{GS}=0$, $f=1\text{MHz}$
Output Capacitance	C_{OSS}	-	9	-		
Reverse Transfer Capacitance	C_{RSS}	-	4	-		
Turn-on Delay Time	$T_{d(on)}$	-	15	-	nS	$V_{DD}=5\text{V}$, $V_{GS}=5\text{V}$, $R_g=10\Omega$, $R_L=500\Omega$, $I_D=10\text{mA}$
Rise Time	T_r	-	35	-		
Turn-off Delay Time	$T_{d(off)}$	-	80	-		
Fall Time	T_f	-	80	-		

Notes:

1. These parameters have no way to verify

CHARACTERISTIC CURVES

