

RoHS Compliant Product
A suffix of "-C" specifies halogen free

DESCRIPTION

The SSD22N15SV-C is the Shielded Gate Technology N-ch MOSFETs with extreme high cell density, which provide excellent $R_{DS(ON)}$ and gate charge for most of the synchronous buck converter applications.

The SSD22N15SV-C meet the RoHS and Green Product requirement with full function reliability approved.

FEATURES

- Shielded Gate Trench Technology
- High Speed Power Switching
- Super Low Gate Charge
- Green Device Available

MARKING

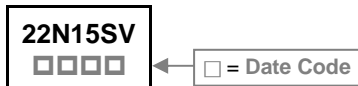

TO-252(D-Pack)

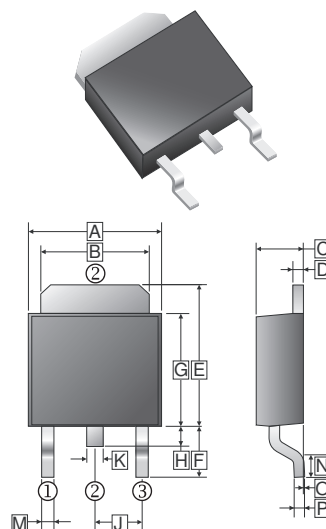

PACKAGE INFORMATION

Package	MPQ	Leader Size
TO-252	2.5K	13 inch

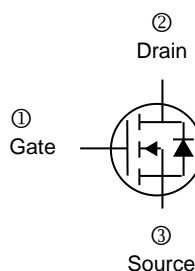

REF.	Millimeter		REF.	Millimeter	
	Min.	Max.		Min.	Max.
A	6.3	6.9	J	2.3	REF.
B	4.95	5.53	K	0.89	REF.
C	2.1	2.5	M	0.45	1.14
D	0.4	0.9	N	1.55	Typ.
E	6	7.7	O	0	0.15
F	2.90	REF.	P	0.58	REF.
G	5.4	6.4			
H	0.6	1.2			

ORDER INFORMATION

Part Number	Type
SSD22N15SV-C	Lead (Pb)-free and Halogen-free

ABSOLUTE MAXIMUM RATINGS

Parameter	Symbol	Ratings	Unit
Drain-Source Voltage	V_{DS}	150	V
Gate-Source Voltage	V_{GS}	± 20	V
Continuous Drain Current ¹ @ $V_{GS}=10V$	I_D	$T_C=25^\circ C$	22
		$T_C=100^\circ C$	14
Pulsed Drain Current ²	I_{DM}	74	A
Total Power Dissipation ³	P_D	39	W
Operating Junction & Storage Temperature Range	T_J, T_{STG}	-55~150	$^\circ C$
Thermal Resistance Ratings			
Thermal Resistance Junction-Ambient ¹	$R_{\theta JA}$	62.5	$^\circ C/W$
Thermal Resistance Junction-Case ¹	$R_{\theta JC}$	3.2	

ELECTRICAL CHARACTERISTICS ($T_J=25^\circ\text{C}$ unless otherwise specified)

Parameter	Symbol	Min.	Typ.	Max.	Unit	Test Conditions	
Drain-Source Breakdown Voltage	BV_{DSS}	150	-	-	V	$V_{GS}=0, I_D=250\mu\text{A}$	
Gate Threshold Voltage	$V_{GS(th)}$	2	-	4	V	$V_{DS}=V_{GS}, I_D=250\mu\text{A}$	
Forward Transconductance	g_{fs}	-	25	-	S	$V_{DS}=5\text{V}, I_D=6\text{A}$	
Gate-Source Leakage Current	I_{GSS}	-	-	± 100	nA	$V_{GS}= \pm 20\text{V}$	
Drain-Source Leakage Current	I_{DSS}	$T_J=25^\circ\text{C}$	-	-	1	μA	$V_{DS}=120\text{V}, V_{GS}=0$
		$T_J=55^\circ\text{C}$	-	-	5		$V_{DS}=120\text{V}, V_{GS}=0$
Static Drain-Source On-Resistance ²	$R_{DS(ON)}$	-	47	58	m Ω	$V_{GS}=10\text{V}, I_D=6\text{A}$	
Total Gate Charge	Q_g	-	23	-	nC	$I_D=6\text{A}$ $V_{DS}=75\text{V}$ $V_{GS}=10\text{V}$	
Gate-Source Charge	Q_{gs}	-	5.8	-			
Gate-Drain Charge	Q_{gd}	-	4.2	-			
Turn-on Delay Time	$T_{d(on)}$	-	16.2	-	nS	$V_{DD}=75\text{V}$ $I_D=6\text{A}$ $V_{GS}=10\text{V}$ $R_G=3.3\Omega$	
Rise Time	T_r	-	18.6	-			
Turn-off Delay Time	$T_{d(off)}$	-	28.5	-			
Fall Time	T_f	-	6.5	-			
Input Capacitance	C_{iss}	-	1190	-	pF	$V_{GS}=0$ $V_{DS}=75\text{V}$ $f=1\text{MHz}$	
Output Capacitance	C_{oss}	-	73	-			
Reverse Transfer Capacitance	C_{rss}	-	4	-			
Source-Drain Diode							
Diode Forward Voltage ²	V_{SD}	-	-	1.2	V	$V_{GS}=0, I_S=1\text{A}$	
Continuous Source Current ¹	I_S	-	-	22	A	$V_G=V_D=0$, Force Current	
Reverse Recovery Time	T_{rr}	-	45	-	nS	$I_F=6\text{A}, dI/dt=100\text{A}/\mu\text{s}$,	
Reverse Recovery Charge	Q_{rr}	-	138	-	nC	$T_J=25^\circ\text{C}$	

Notes:

1. The data tested by surface mounted on a 1inch² FR4 Board with 2OZ copper.
2. The data tested by pulsed, Pulse Width $\leq 300\mu\text{s}$, Duty Cycle $\leq 2\%$.
3. The power dissipation is limited by 150 $^\circ\text{C}$, junction temperature.

TYPICAL CHARACTERISTICS CURVE

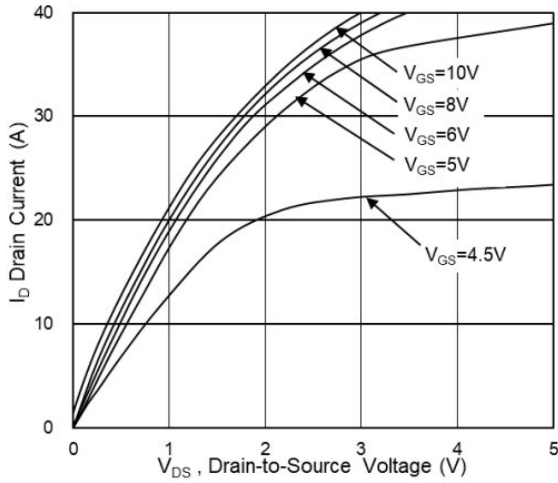

Fig.1 Typical Output Characteristics

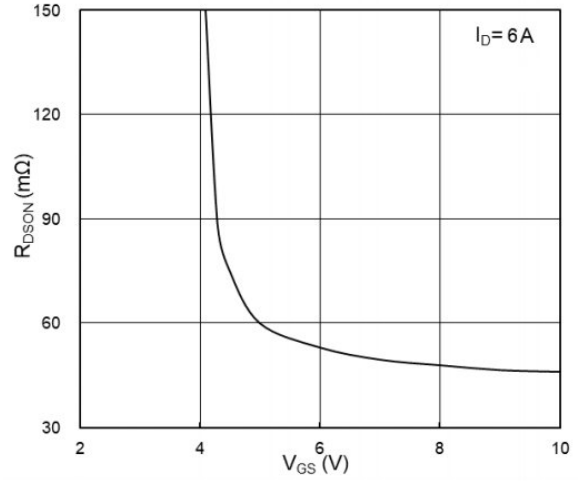

Fig.2 On-Resistance vs G-S Voltage

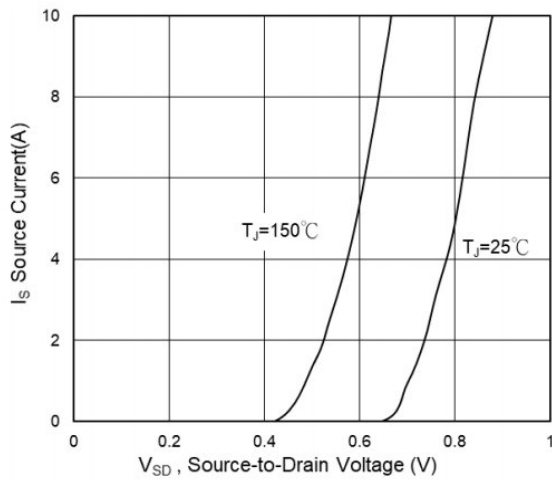

Fig.3 Source Drain Forward Characteristics

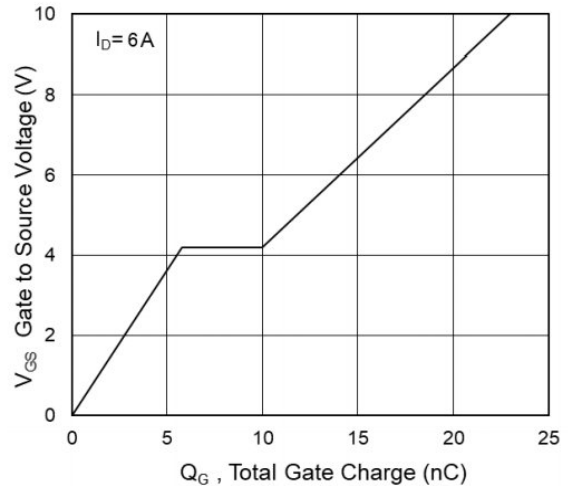

Fig.4 Gate-Charge Characteristics

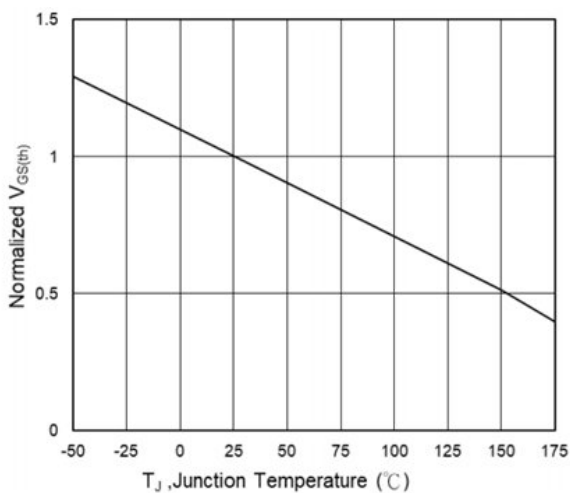

Fig.5 Normalized V_{GS(th)} vs T_J

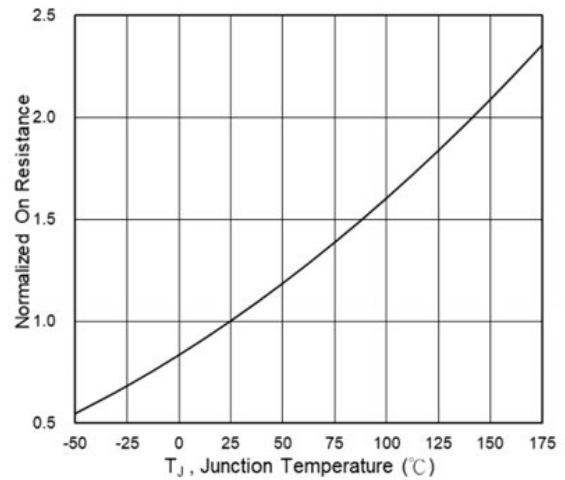

Fig.6 Normalized R_{DS(ON)} vs T_J

TYPICAL CHARACTERISTICS CURVE

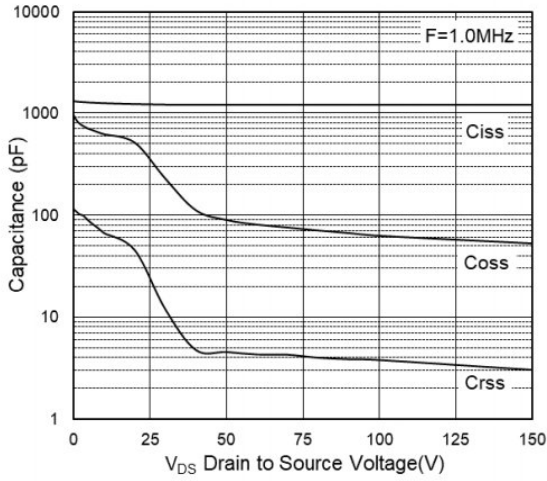

Fig.7 Capacitance

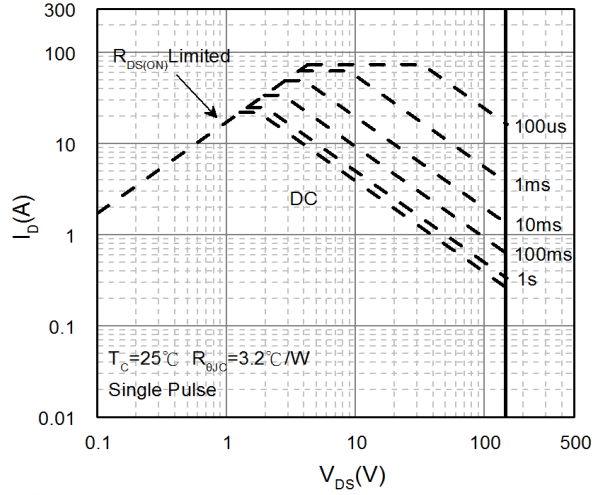

Fig.8 Safe Operating Area

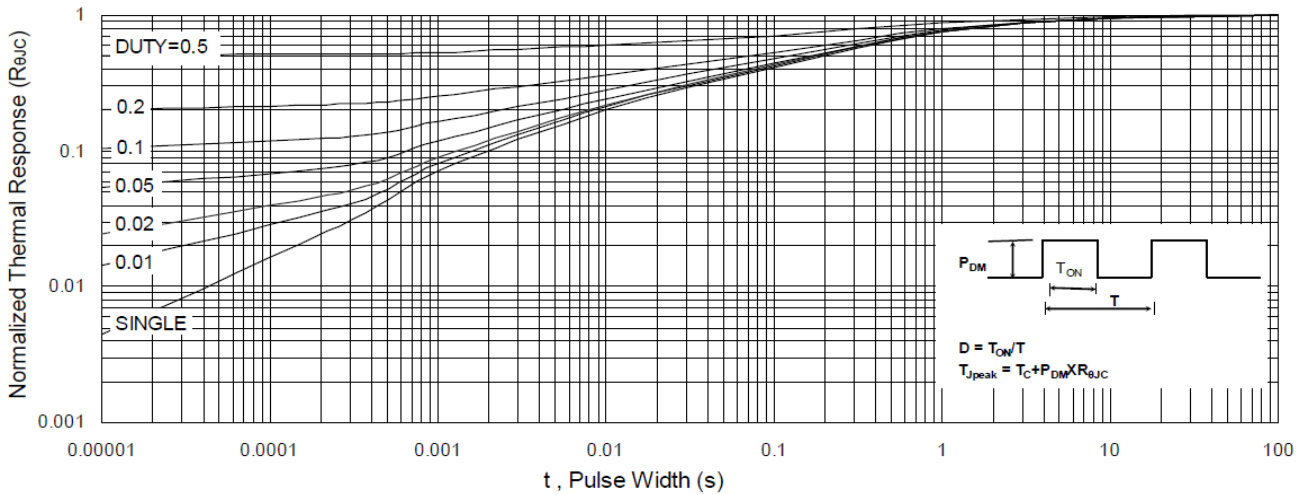

Fig.9 Normalized Maximum Transient Thermal Impedance

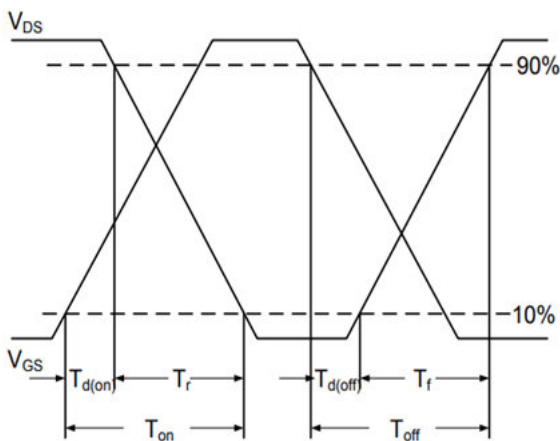

Fig.10 Switching Time Waveform

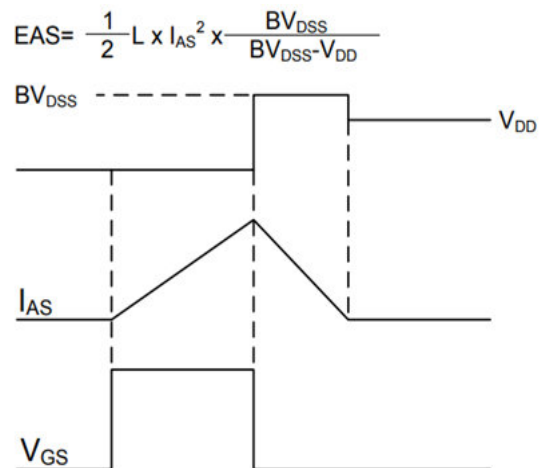

Fig.11 Unclamped Inductive Switching Waveform