

RoHS Compliant Product

SOT-223

Description

The PZTA94 is designed for application requires high voltage.

Features

- *High Current Gain: $I_C=300\text{mA}$ at 25°C
- *High Voltage: $V_{CE0}=400\text{V}$ (min) at $I_C=1\text{mA}$
- *Complementary With PZTA44

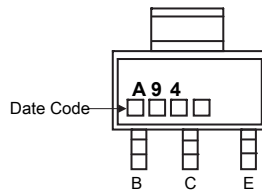
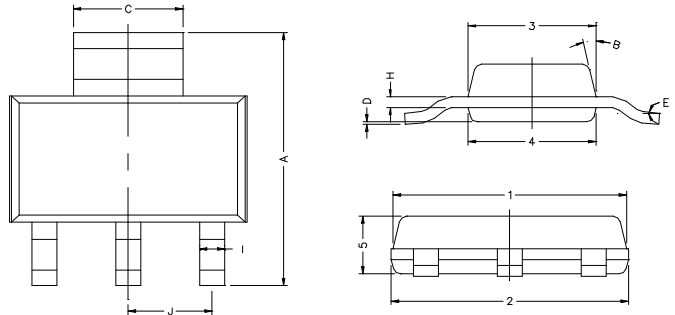

REF.	Millimeter		REF.	Millimeter	
	Min.	Max.		Min.	Max.
A	6.70	7.30	B	13 TYP.	
C	2.90	3.10	J	2.30 REF.	
D	0.02	0.10	1	6.30	6.70
E	0 ^ˆ	10 ^ˆ	2	6.30	6.70
I	0.60	0.80	3	3.30	3.70
H	0.25	0.35	4	3.30	3.70
			5	1.40	1.80

ABSOLUTE MAXIMUM RATINGS $T_a=25^\circ\text{C}$

Symbol	Parameter	Value	Units
V_{CBO}	Collector-Base Voltage	-400	V
V_{CEO}	Collector-Emitter Voltage	-400	V
V_{EBO}	Emitter-Base Voltage	-6	V
I_C	Collector Current	-500	mA
P_D	Total Power Dissipation	2	W
T_J, T_{stg}	Junction and Storage Temperature	-55~+150	$^\circ\text{C}$

ELECTRICAL CHARACTERISTICS $T_{amb}=25^\circ\text{C}$ unless otherwise specified

Parameter	Symbol	Min	Typ.	Max	Unit	Test Conditions
Collector-Base Breakdown Voltage	BV_{CBO}	-400	-	-	V	$I_C=-100\mu\text{A}, I_E=0$
Collector-Emitter Breakdown Voltage	BV_{CEO}	-400	-	-	V	$I_C=-1\text{mA}, I_B=0$
Emitter-Base Breakdown Voltage	BV_{EBO}	-6	-	-	V	$I_E=-100\mu\text{A}, I_C=0$
Collector-Base Cutoff Current	I_{CBO}	-	-	-100	nA	$V_{CB}=-400\text{V}, I_E=0$
Emitter-Base Cutoff Current	I_{EBO}	-	-	-100	nA	$V_{BE}=-6\text{V}, I_C=0$
Collector-Base Cutoff Current	I_{CES}	-	-	-500	nA	$V_{CE}=-400\text{V}, V_{BE}=0$
Collector Saturation Voltage	* $V_{CE(sat)1}$	-	-	-350	mV	$I_C=-1\text{mA}, I_B=-0.1\text{mA}$
	* $V_{CE(sat)2}$	-	-	-500	mV	$I_C=-10\text{mA}, I_B=-1\text{mA}$
	* $V_{CE(sat)3}$	-	-	-750	mV	$I_C=-50\text{mA}, I_B=-5\text{mA}$
Base Saturation Voltage	$V_{BE(sat)}$	-	-	-750	mV	$I_C=-10\text{mA}, I_B=-1\text{mA}$
DC Current Gain	* h_{FE1}	40	-	-		$V_{CE}=-10\text{V}, I_C=-1\text{mA}$
	* h_{FE2}	50	-	300		$V_{CE}=-10\text{V}, I_C=-10\text{mA}$
	* h_{FE3}	45	-	-		$V_{CE}=-10\text{V}, I_C=-50\text{mA}$
	* h_{FE4}	40	-	-		$V_{CE}=-10\text{V}, I_C=-100\text{mA}$

*Pulse width $\leq 380\mu\text{s}$, Duty Cycle $\leq 2\%$

Characteristics Curve

