

RoHS Compliant Product
A suffix of "-C" specifies halogen & lead-free

FEATURES

- Simplifies Circuit Design.
- We Declare that the material of product compliance with RoHS requirements.

MARKING

2A

3N

PACKAGE INFORMATION

Package	MPQ	Leader Size
SOT-523	3K	7 inch

ORDER INFORMATION

Part Number	Type
MMBT3906FW	Lead (Pb)-free
MMBT3906FW-C	Lead (Pb)-free and Halogen-free

SOT-523

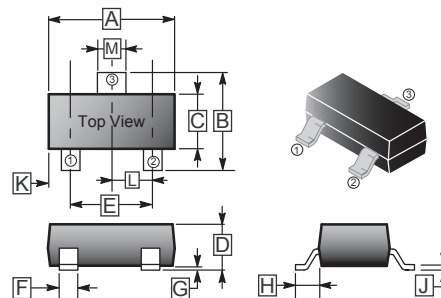

REF.	Millimeter		REF.	Millimeter	
	Min.	Max.		Min.	Max.
A	1.5	1.7	G	-	0.1
B	1.45	1.75	H	0.55 REF.	
C	0.7	0.9	J	0.1	0.2
D	0.7	0.9	K	-	
E	0.9	1.1	L	0.5 TYP.	
F	0.15	0.25	M	0.25	0.35

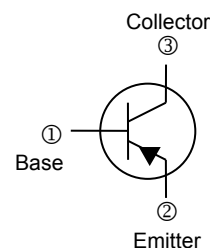

MAXIMUM RATINGS (at $T_a = 25^\circ\text{C}$ unless otherwise specified)

Parameter	Symbol	Ratings	Unit
Collector - Emitter Voltage	V_{CEO}	-40	Vdc
Collector - Base Voltage	V_{CBO}	-40	Vdc
Emitter - Base Voltage	V_{EBO}	-5	Vdc
Collector Current - Continuous	I_C	-200	mAdc
Total Device Dissipation FR-4 Board ⁽¹⁾ $T_A=25^\circ\text{C}$, Derate above 25°C	P_D	200	mW
		1.6	mW/ $^\circ\text{C}$
Thermal Resistance, Junction to Ambient	$R_{\theta JA}$	600	$^\circ\text{C} / \text{W}$
Total Device Dissipation FR-4 Board ⁽²⁾ $T_A=25^\circ\text{C}$, Derate above 25°C	P_D	300	mW
		2.4	mW/ $^\circ\text{C}$
Thermal Resistance, Junction to Ambient	$R_{\theta JA}$	400	$^\circ\text{C} / \text{W}$
Junction & Storage Temperature	T_J, T_{STG}	-55 ~ 150	$^\circ\text{C}$

Note:

1. FR-4 Minimum Pad.
2. FR-4 1.0 X 1.0 Inch Pad.
3. Pulse Test : Pulse Width $\leq 300 \mu\text{s}$, Duty Cycle $\leq 2.0\%$.

ELECTRICAL CHARACTERISTICS (at $T_a = 25^\circ\text{C}$ unless otherwise specified)

Parameter	Symbol	Min.	Max.	Unit	Test conditions
Off Characteristics					
Collector-Emitter Breakdown Voltage ¹	$V_{(BR)CEO}$	-40	-	V	$I_C = -1.0\text{ mA}, I_B = 0$
Collector-Base Breakdown Voltage	$V_{(BR)CBO}$	-40	-	V	$I_C = -10\text{ }\mu\text{A}, I_E = 0$
Emitter-Base Breakdown Voltage	$V_{(BR)EBO}$	-5.0	-	V	$I_E = -10\text{ }\mu\text{A}, I_C = 0$
Collector Cut-Off Current	I_{BL}	-	-50	nA	$V_{CE} = -30\text{ V}, V_{EB} = -3\text{ V}$
Emitter Cut-Off Current	I_{CEX}	-	-50	nA	$V_{CE} = -30\text{ V}, V_{EB} = -3\text{ V}$
On Characteristics⁽¹⁾					
DC Current Gain ⁽¹⁾	h_{FE}	60	-		$I_C = -0.1\text{ mA}, V_{CE} = -1\text{ V}$
		80	-		$I_C = -1\text{ mA}, V_{CE} = -1\text{ V}$
		100	300		$I_C = -10\text{ mA}, V_{CE} = -1\text{ V}$
		60	-		$I_C = -50\text{ mA}, V_{CE} = -1\text{ V}$
		30	-		$I_C = -100\text{ mA}, V_{CE} = -1\text{ V}$
Collector-Emitter Saturation Voltage ¹	$V_{CE(sat)}$	-	-0.25	V	$I_C = -10\text{ mA}, I_B = -1\text{ mA}$
		-	-0.4		$I_C = -50\text{ mA}, I_B = -5\text{ mA}$
Base-Emitter Saturation Voltage ¹	$V_{BE(sat)}$	-0.65	-0.85	V	$I_C = -10\text{ mA}, I_B = -1\text{ mA}$
		-	-0.95		$I_C = -50\text{ mA}, I_B = -5\text{ mA}$
Small-Signal Characteristics					
Current-Gain-Bandwidth Product	f_T	250	-	MHz	$V_{CE} = -20\text{ V}, I_C = -10\text{ mA}, f = 100\text{ MHz}$
Output Capacitance	C_{obo}	-	4.5	pF	$V_{CB} = -5.0\text{ V}, I_E = 0, f = 1\text{ MHz}$
Input Capacitance	C_{ibo}	-	10	pF	$V_{EB} = -0.5\text{ V}, I_E = 0, f = 1\text{ MHz}$
Input Impedance	h_{ie}	2.0	12	pF	$V_{CE} = -10\text{ V}, I_C = -1\text{ mA}, f = 1\text{ kHz}$
Voltage Feedback Ratio	h_{re}	0.1	10	$\times 10^{-4}$	$V_{CE} = -10\text{ V}, I_C = -1\text{ mA}, f = 1\text{ kHz}$
Small-Signal Current Gain	h_{fe}	100	400	-	$V_{CE} = -10\text{ V}, I_C = -1\text{ mA}, f = 1\text{ kHz}$
Output Admittance	$*h_{oe}$	3.0	60	μmhos	$V_{CE} = -10\text{ V}, I_C = -1\text{ mA}, f = 1\text{ kHz}$
Noise Figure	NF	-	4.0	dB	$V_{CE} = -5\text{ V}, I_C = -100\text{ }\mu\text{A}, R_S = 1\text{ k }\Omega, f = 1\text{ kHz}$
Switching Characteristics					
Delay Time	T_d	-	35	nS	$V_{CC} = -3\text{ V}, V_{BE} = -0.5\text{ V}, I_C = -10\text{ mA}, I_{B1} = -1\text{ mA}$
Rise Time	T_r	-	35	nS	
Storage Time	T_s	-	225	nS	$V_{CC} = -3\text{ V}, I_C = -10\text{ mA}, I_{B1} = I_{B2} = -1\text{ mA}$
Fall Time	T_f	-	75	nS	

Note:

1. Pulse Test : Pulse Width $\leq 300\text{ }\mu\text{s}$, Duty Cycle $\leq 2.0\%$.

CHARACTERISTIC CURVES

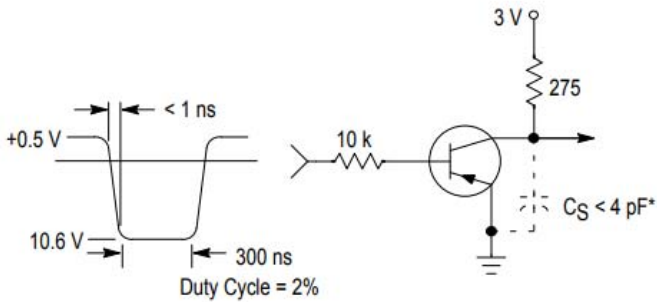

Figure 1. Delay and Rise Time Equivalent Test Circuit

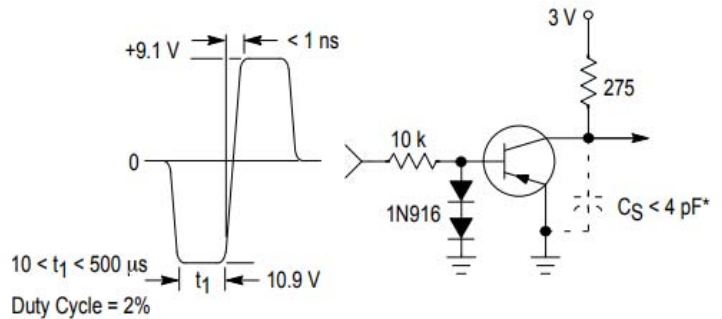

Figure 2. Storage and Fall Time Equivalent Test Circuit

* Total shunt capacitance of test jig and connectors

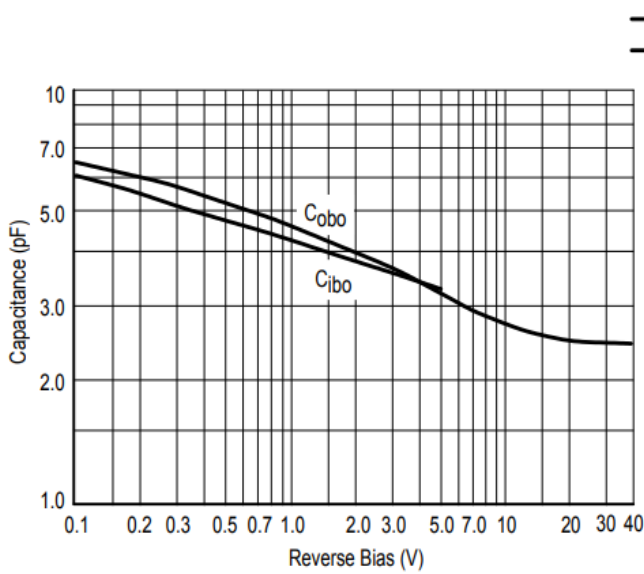

Figure 3. Capacitance

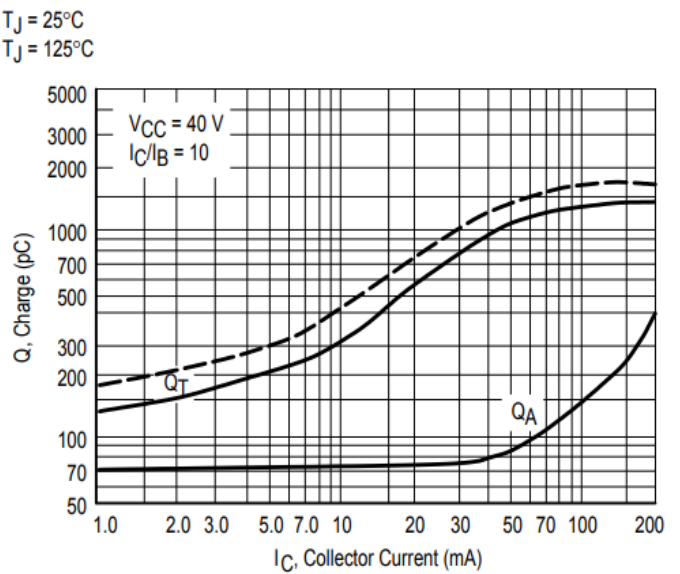

Figure 4. Charge Data

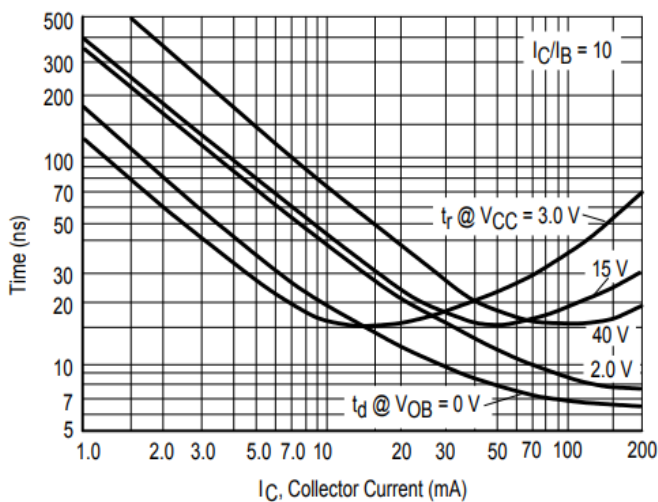

Figure 5. Turn-On Time

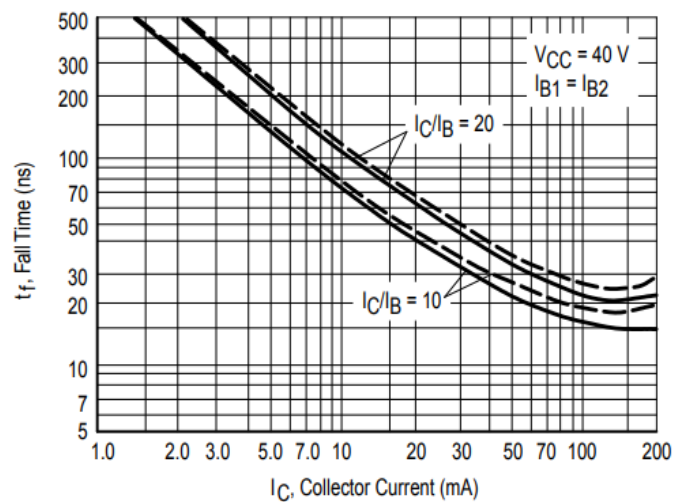

Figure 6. Fall Time

CHARACTERISTIC CURVES

**TYPICAL AUDIO SMALL-SIGNAL CHARACTERISTICS
NOISE FIGURE VARIATIONS**

($V_{CE} = -5.0$ Vdc, $T_A = 25^\circ\text{C}$, Bandwidth = 1.0 Hz)

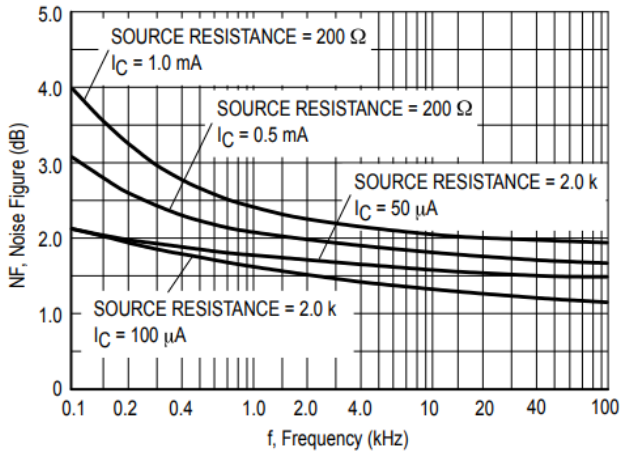

Figure 7.

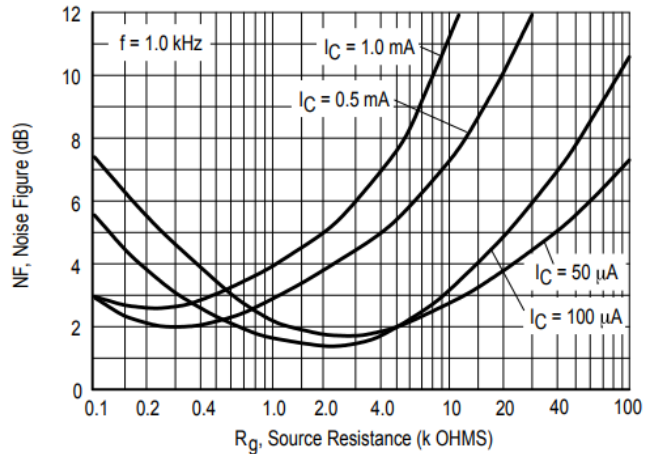

Figure 8.

h PARAMETERS

($V_{CE} = -10$ Vdc, $f = 1.0$ kHz, $T_A = 25^\circ\text{C}$)

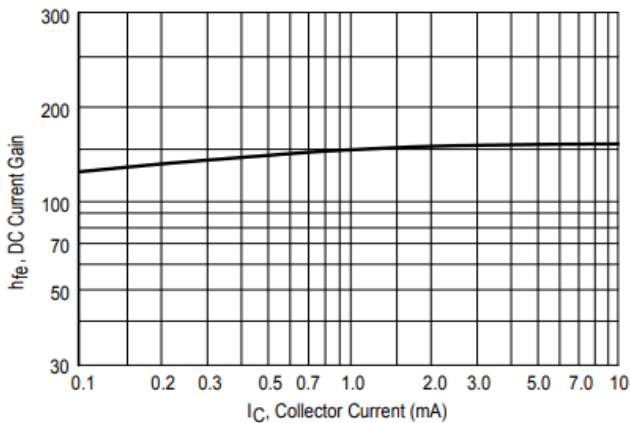

Figure 9. Current Gain

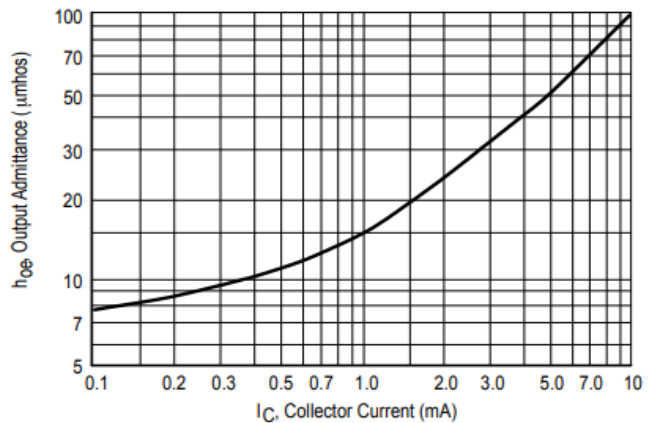

Figure 10. Output Admittance

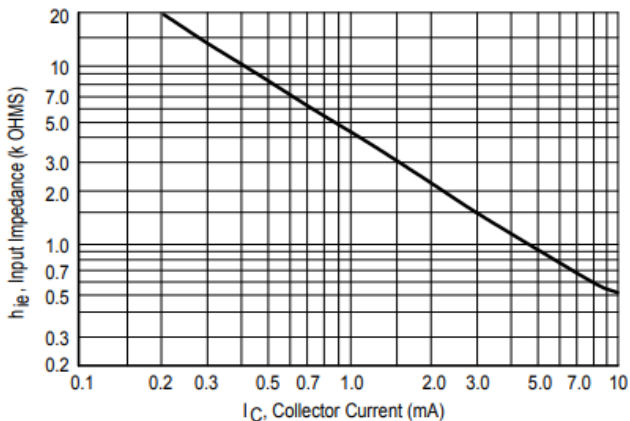

Figure 11. Input Impedance

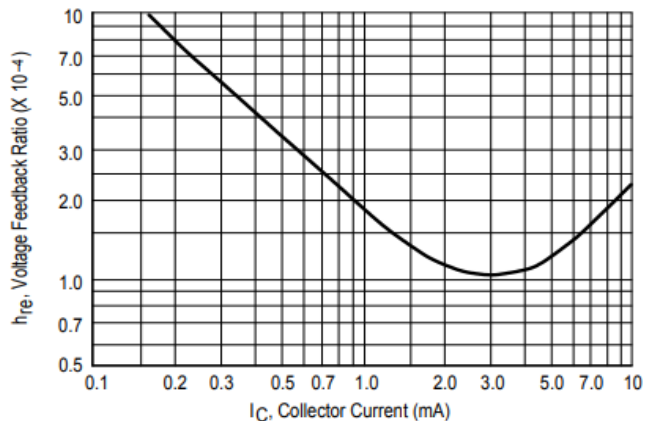

Figure 12. Voltage Feedback Ratio

CHARACTERISTIC CURVES

TYPICAL STATIC CHARACTERISTICS

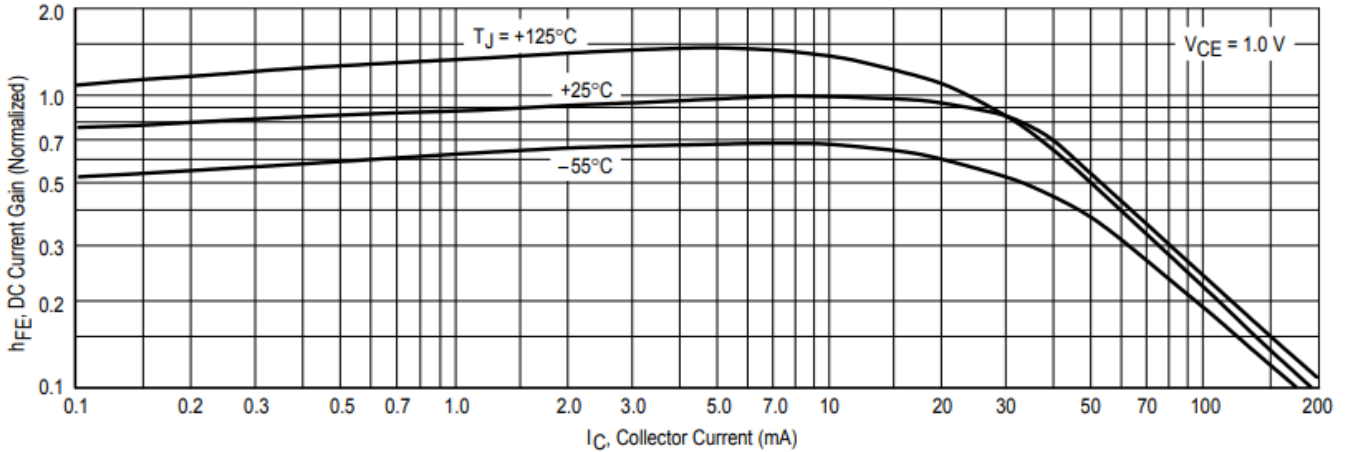

Figure 13. DC Current Gain

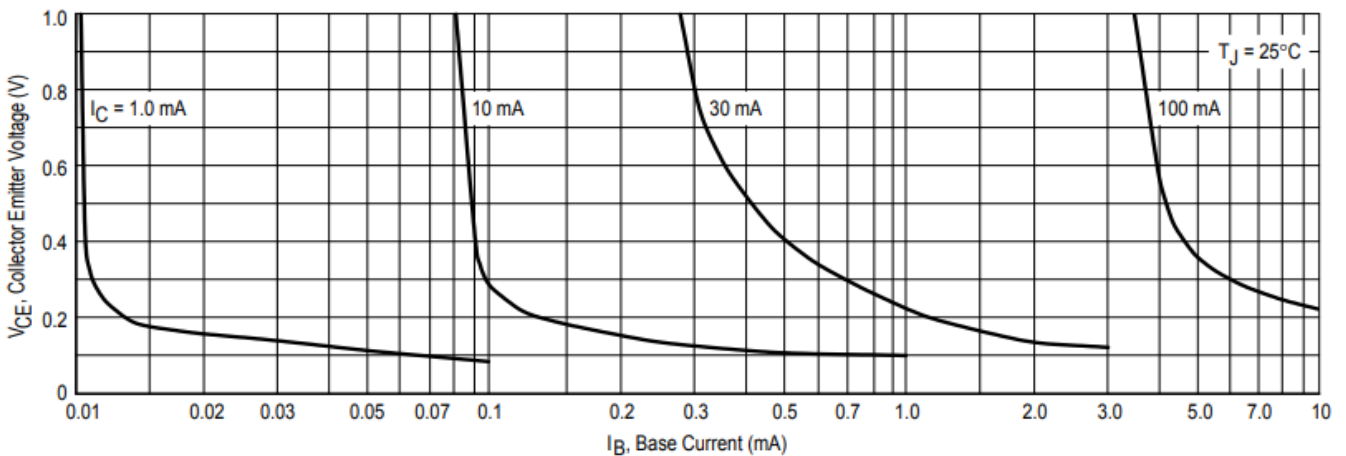

Figure 14. Collector Saturation Region

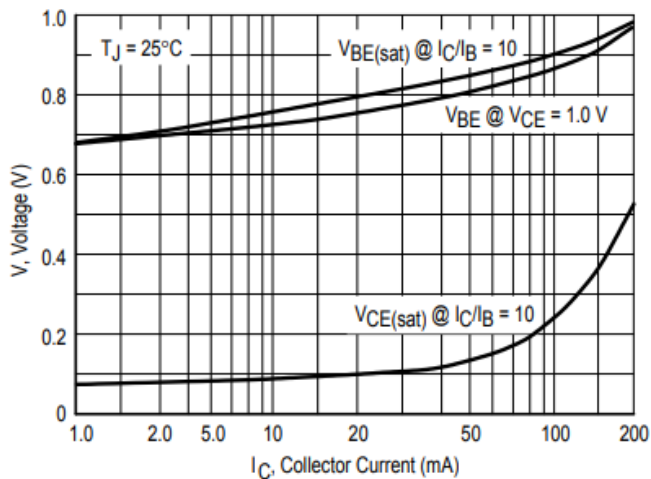

Figure 15. "ON" Voltages

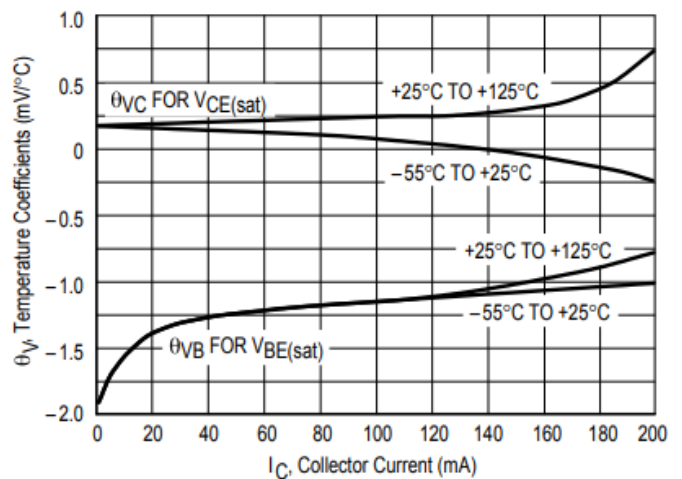

Figure 16. Temperature Coefficients