

RoHS Compliant Product  
A suffix of "-C" specifies halogen & lead-free

## FEATURES

- The BCP4672 is designed for low frequency amplifier applications.

## MARKING

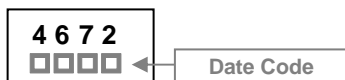

## SOT-89

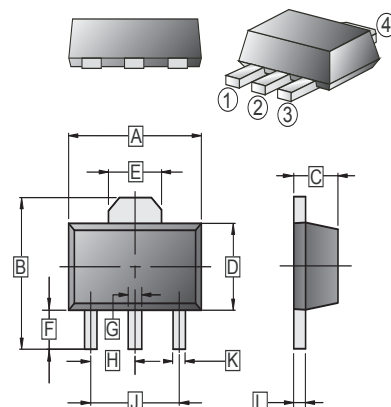

## CLASSIFICATION OF $h_{FE}$

Product Rank	BCP4672-A	BCP4672-B
Range	120~240	200~400

## PACKAGE INFORMATION

Package	MPQ	LeaderSize
SOT-89	1K	7' inch

REF.	Millimeter		REF.	Millimeter	
	Min.	Max.		Min.	Max.
A	4.40	4.60	G	0.40	0.58
B	3.94	4.25	H	1.50	TYP
C	1.40	1.60	J	3.00	TYP
D	2.30	2.60	K	0.32	0.52
E	1.50	1.70	L	0.35	0.44
F	0.89	1.2			

## ABSOLUTE MAXIMUM RATINGS ( $T_A = 25^\circ\text{C}$ unless otherwise specified)

Parameter	Symbol	Ratings	Unit
Collector-Base Voltage	$V_{CB0}$	60	V
Collector-Emitter Voltage	$V_{CEO}$	50	V
Emitter-Base Voltage	$V_{EBO}$	6	V
Collector Current (DC)	$I_C$	2	A
Collector Current (Pulse)		5	
Total Power Dissipation	$P_D$	2	W
Junction & Storage Temperature	$T_J, T_{STG}$	150, -55~150	$^\circ\text{C}$

## ELECTRICAL CHARACTERISTICS ( $T_A = 25^\circ\text{C}$ unless otherwise specified)

Parameter	Symbol	Min.	Typ.	Max.	Unit	Test Conditions
Collector-base breakdown voltage	$V_{(BR)CBO}$	60	-	-	V	$I_C = 50\mu\text{A}, I_E = 0$
Collector-emitter breakdown voltage	$V_{(BR)CEO}$	50	-	-	V	$I_C = 1\text{mA}, I_B = 0$
Emitter-base breakdown voltage	$V_{(BR)EBO}$	6	-	-	V	$I_E = 50\mu\text{A}, I_C = 0$
Collector cut-off current	$I_{CBO}$	-	-	100	nA	$V_{CB} = 60\text{V}, I_E = 0$
Emitter cut-off current	$I_{EBO}$	-	-	100	nA	$V_{EB} = 5\text{V}, I_C = 0$
Collector-emitter saturation voltage	$V_{CE(sat)}^*$	-	0.1	0.35	V	$I_C = -1\text{A}, I_B = 50\text{mA}$
DC current gain	$h_{FE}^*$	120	-	400		$V_{CE} = 2\text{V}, I_C = 500\text{mA}$
Transition frequency	$f_T$	-	210	-	MHz	$V_{CE} = 2\text{V}, I_C = 500\text{mA}, f = 100\text{MHz}$
Collector output capacitance	$C_{ob}$	-	25	-	pF	$V_{CB} = 10\text{V}, I_E = 0, f = 1\text{MHz}$

\*Measured under pulse condition. Pulse width  $\leq 380\mu\text{s}$ , Duty Cycle  $\leq 2\%$ .

**CHARACTERISTIC CURVES**

