

RoHS Compliant Product

A suffix of "-C" specifies halogen & lead-free

Features

* Amplifier and switching applications

MAXIMUM RATINGS* $T_A=25^\circ\text{C}$ unless otherwise noted

Symbol	Parameter	Value	Units
V_{CBO}	Collector-Base Voltage	BD439 60 BD441 80	V
	Collector-Emitter Voltage	BD439 60 BD441 80	V
V_{EBO}	Emitter-Base Voltage	5	V
I_C	Collector Current –Continuous	4	A
P_C	Collector Dissipation	1.25	W
T_J	Junction Temperature	150	$^\circ\text{C}$
T_{stg}	Storage Temperature	-55-150	$^\circ\text{C}$

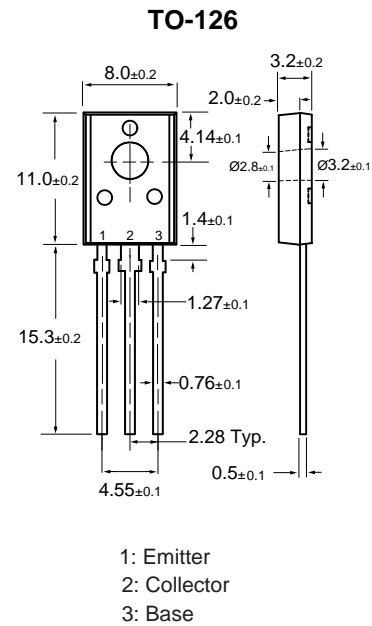

Dimensions in Millimeters

ELECTRICAL CHARACTERISTICS ($T_{amb}=25^\circ\text{C}$ unless otherwise specified)

Parameter	Symbol	Test conditions	MIN	TYP	MAX	UNIT
Collector-base breakdown voltage	$V_{(BR)CBO}$	$I_C=100\ \mu\text{A}, I_E=0$	BD439 60			V
			BD441 80			
Collector-emitter breakdown voltage	$V_{(BR)CEO}$	$I_C=100\text{mA}, I_B=0$	BD439 60			V
			BD441 80			
Emitter-base breakdown voltage	$V_{(BR)EBO}$	$I_E=100\ \mu\text{A}, I_C=0$	5			V
Collector cut-off current	I_{CBO}	$V_{CB}=60\text{V}, I_E=0$	BD439		100	μA
		$V_{CB}=80\text{V}, I_E=0$	BD441			
Emitter cut-off current	I_{EBO}	$V_{EB}=5\text{V}, I_E=0$			1	mA
DC current gain	$h_{FE(1)}$	$V_{CE}=1\text{V}, I_C=500\text{mA}$		40	475	
	$h_{FE(2)}$	$V_{CE}=5\text{V}, I_C=10\text{mA}$	BD439	20		
			BD441	15		
$h_{FE(3)}$	$V_{CE}=1\text{V}, I_C=2\text{A}$	BD439 25 BD441 15				
Collector-emitter saturation voltage	$V_{CE(sat)}$	$I_C=3\text{A}, I_B=0.3\text{A}$			0.8	V
Base-emitter voltage	V_{BE}	$V_{CE}=1\text{V}, I_C=2\text{A}$			1.1	V
Transition frequency	f_T	$V_{CE}=1\text{V}, I_C=250\text{mA}$	3			MHz

Typical Characteristics

BD439, 441

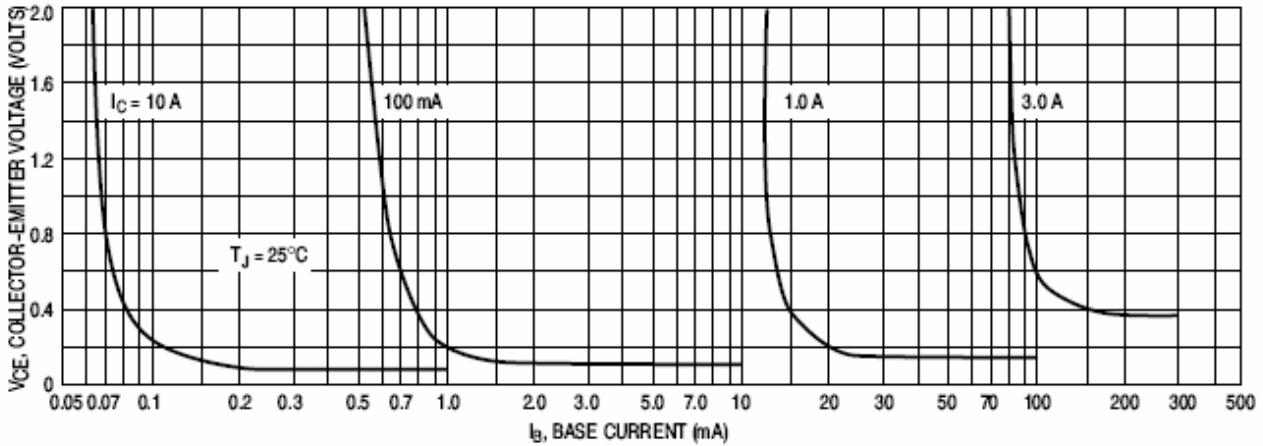

Figure 1. Collector Saturation Region

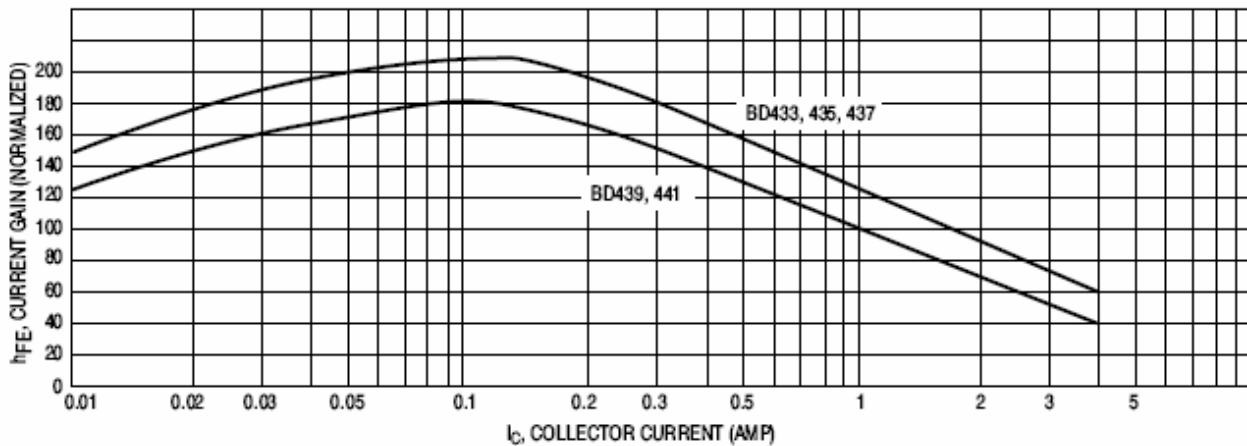

Figure 2. Current Gain

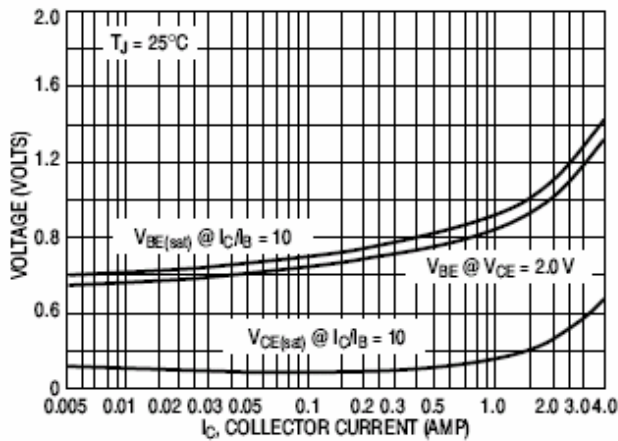

Figure 3. "On" Voltage

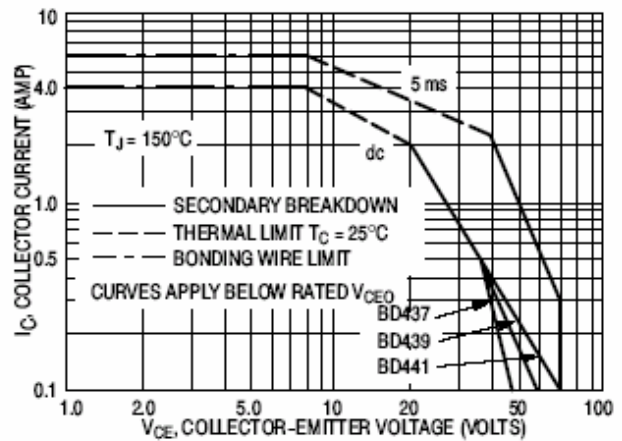

Figure 4. Active Region Safe Operating Area