

RoHS Compliant Product
A suffix of "-C" specifies halogen & lead-free

FEATURES

- High Current Capability
- High DC Current Gain
- Small Package

APPLICATIONS

- Audio Amplifier Applications
- AM Amplifier Applications

CLASSIFICATION OF h_{FE}

Product-Rank	2SC3199-O	2SC3199-Y	2SC3199-GR
Range	70~140	120~240	200~400

TO-92S

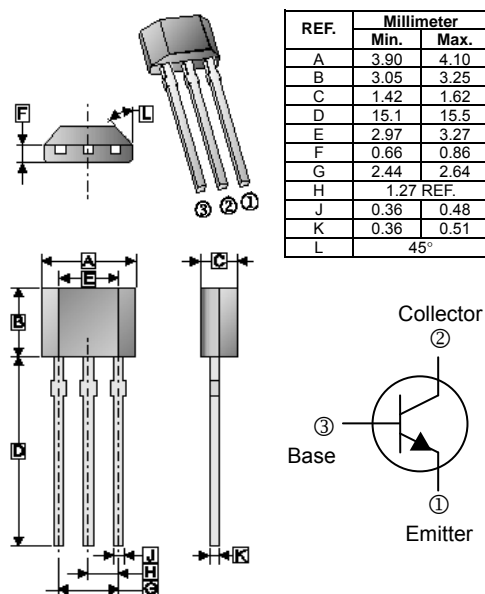

ABSOLUTE MAXIMUM RATINGS ($T_A=25^\circ\text{C}$ unless otherwise specified)

Parameter	Symbol	Rating	Unit
Collector to Base Voltage	V_{CBO}	50	V
Collector to Emitter Voltage	V_{CEO}	50	V
Emitter to Base Voltage	V_{EBO}	5	V
Collector Current - Continuous	I_C	150	mA
Collector Power Dissipation	P_C	400	mW
Thermal Resistance From Junction To Ambient	$R_{\theta JA}$	312	$^\circ\text{C} / \text{W}$
Junction, Storage Temperature	T_J, T_{STG}	150, -55~150	$^\circ\text{C}$

ELECTRICAL CHARACTERISTICS ($T_A = 25^\circ\text{C}$ unless otherwise specified)

Parameter	Symbol	Min.	Typ.	Max.	Unit	Test Condition
Collector to Base Breakdown Voltage	$V_{(BR)CBO}$	50	-	-	V	$I_C=0.1\text{mA}, I_E=0$
Collector to Emitter Breakdown Voltage	$V_{(BR)CEO}$	50	-	-	V	$I_C=1\text{mA}, I_B=0$
Emitter to Base Breakdown Voltage	$V_{(BR)EBO}$	5	-	-	V	$I_E=0.1\text{mA}, I_C=0$
Collector Cut - Off Current	I_{CBO}	-	-	0.1	μA	$V_{CB}=50\text{V}, I_E=0$
Emitter Cut - Off Current	I_{EBO}	-	-	0.1	μA	$V_{EB}=5\text{V}, I_C=0$
DC Current Gain	h_{FE}	70	-	400		$V_{CE}=6\text{V}, I_C=2\text{mA}$
Collector to Emitter Saturation Voltage	$V_{CE(sat)}$	-	-	0.25	V	$I_C=100\text{mA}, I_B=10\text{mA}$
Collector Output Capacitance	C_{ob}	-	-	3.5	pF	$V_{CB}=10\text{V}, I_E=0, f=1\text{MHz}$
Transition Frequency	f_T	80	-	-	MHz	$V_{CE}=10\text{V}, I_C=1\text{mA}$