

RoHS Compliant Product
A suffix of "-C" specifies halogen & lead-free

FEATURES

- Low leakage
- Low forward voltage drop
- Super long operating life
- Plastic package has Underwriters Laboratory Flammability Classification 94V-0

PACKAGE INFORMATION

Package	MPQ	LeaderSize
TO-277A	4K	13' inch

TO-277A

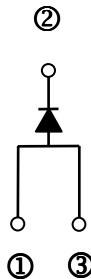
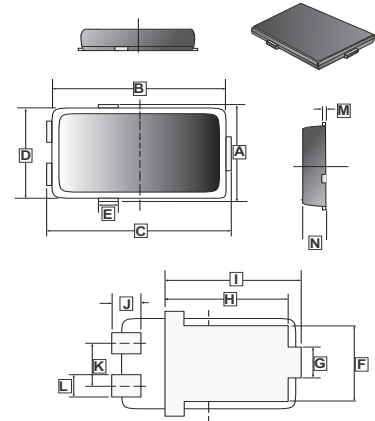

REF.	Millimeter		REF.	Millimeter	
	Min.	Max.		Min.	Max.
A	4.4	4.8	H	4.05 Typ.	
B	5.9	6.3	J	4.4	4.8
C	6.3	6.7	K	2.0	2.2
D	4.1	4.5	L	1.0	1.4
E	0.65 Typ.		M	0.15	0.35
F	3.55	3.95	N	1.0	1.4
G	1.85	2.25			

MAXIMUM RATINGS AND ELECTRICAL CHARACTERISTICS

Rating 25°C ambient temperature unless otherwise specified. Single phase, half wave, 60Hz, resistive or inductive load.
For capacitive load, derate current by 20%.

Parameters	Symbol	Part numbers			Units	Testing conditions
		SMP640	SMP660	SMP6100		
Maximum Repetitive peak Reverse Voltage	V_{RRM}	40	60	100	V	
Maximum DC Blocking Voltage	V_{DC}	40	60	100	V	
Maximum Forward Voltage	V_F	0.55	0.7	0.85	V	$I_F=6A, T_A=25^\circ C$
		0.5	0.65	0.8	V	$I_F=3A, T_A=125^\circ C$
		0.38	0.58	0.68		
Maximum Average Forward Rectified Current	$I_{F(AV)}$	6			A	$T_L = 90^\circ C$
Peak Forward Surge Current	I_{FSM}	150			A	8.3ms single half sine-wave superimposed on rated load (JEDEC method)
Maximum DC Reverse Current at Rated DC Blocking Voltage	I_{R1}	0.5			mA	$T_A=25^\circ C$
	I_{R2}	1	0.5			$T_A=75^\circ C, 50\%V_{RRM, typ.}$
	I_{R3}	50	30			$T_A=100^\circ C$
Thermal Resistance junction to Ambient	$R_{\theta JA}$	100			K / W	
Thermal Resistance junction to Lead	$R_{\theta JL}$	3			K / W	
Operating Temperature Range	T_J	-55 ~ 150			°C	≤ 1h
In DC forward mode		200 (Note 1)				
Storage Temperature Range	T_{STG}	-55 ~ 150			°C	

Notes :

1. Meets the requirements of IEC 61215 Ed.2 bypass diode thermal test.