

RoHS Compliant Product
A suffix of "-C" specifies halogen or lead -free

DESCRIPTION

The TL432-C is a three-terminal Shunt Voltage Reference providing a highly accurate 1.24V. The TL432-C thermal stability and wide operating current, makes it suitable for all variety of applications that are looking for a low cost solution with high performance.

FEATURES

- Low Dynamic Output Impedance
- Low Output Noise Voltage
- Fast Turn-on Response
- Sink Current Capability of 0.1mA~100mA
- The Effective Temperature Compensation in the Working Range of Full Temperature

APPLICATIONS

- Shunt Regulator
- High-Current Shunt Regulator
- Precision Current Limiter

MARKING

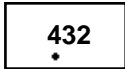

PACKAGE INFORMATION

Package	MPQ	Leader Size
SOT-23	3K	7 inch

ORDER INFORMATION

Part Number	Type
TL432-C	Lead (Pb)-free and Halogen-free

ABSOLUTE MAXIMUM RATINGS (Operating temperature range applies unless otherwise specified)

Parameter	Symbol	Ratings	Unit
Cathode Voltage	V_{KA}	18	V
Cathode Current Range (Continuous)	I_{KA}	100	mA
Reference Input Current Range	I_{ref}	6	μA
Power Dissipation	P_D	350	mW
Thermal Resistance from Junction-Ambient	$R_{\theta JA}$	357	$^{\circ}C/W$
Operating Junction Temperature Range	T_J	-40~125	$^{\circ}C$
Storage Temperature Range	T_{STG}	-65~150	

SOT-23

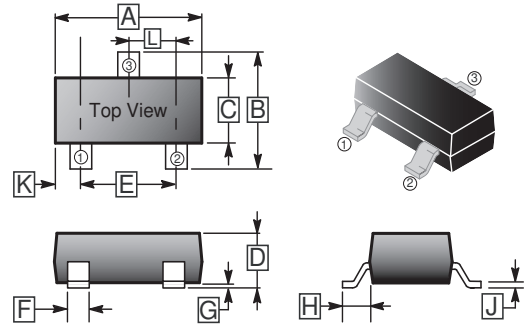

REF.	Millimeter		REF.	Millimeter	
	Min.	Max.		Min.	Max.
A	2.70	3.10	G	0	0.18
B	2.10	2.95	H	0.55	REF.
C	1.20	1.70	J	0.08	0.20
D	0.89	1.30	K	0.60	REF.
E	1.70	2.30	L	0.95	BSC.
F	0.30	0.50			

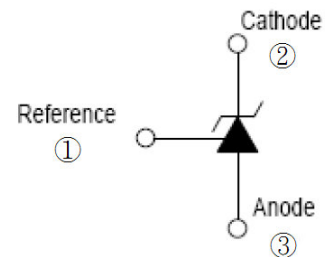

ELECTRICAL CHARACTERISTICS ($T_A=25^{\circ}\text{C}$ unless otherwise specified)

Parameter	Symbol	Min.	Typ.	Max.	Unit	Test Conditions
Reference Input Voltage (Fig.1)	V_{ref}	1.2214	-	1.2586	V	$V_{KA}=V_{ref}$, $I_{KA}=10\text{mA}$
Deviation of Reference Voltage Over Full Temperature Range (Fig.1)	$\Delta V_{ref(DEV)}$	-	-	16	mV	$V_{KA}=V_{ref}$, $I_{KA}=10\text{mA}$ $0^{\circ}\text{C} \leq T_A \leq 70^{\circ}\text{C}$
Ratio of Change in Reference Input Voltage to the Change in Cathode Voltage (Fig.2)	$\Delta V_{ref} / \Delta V_{KA}$	-	-	2.4	mV/V	$I_{KA}=10\text{mA}$, $\Delta V_{KA}=1.25\text{V} \sim 15\text{V}$
Deviation of Reference Input Current Over Full Temperature Range (Fig.2)	$\Delta I_{ref} / \Delta T$	-	-	0.6	μA	$I_{KA}=10\text{mA}$, $R_1=10\text{K}\Omega$, $R_2=\infty$ $0^{\circ}\text{C} \leq T_A \leq 70^{\circ}\text{C}$
Minimum Cathode Current for Regulation (Fig.1)	$I_{KA(min)}$	-	-	0.1	mA	$V_{KA}=V_{ref}$
Off-State Cathode Current (Fig.3)	$I_{KA(OFF)}$	-	-	0.5	μA	$V_{KA}=15\text{V}$, $V_{ref}=0$
Dynamic Impedance	Z_{KA}	-	-	0.5	Ω	$V_{KA}=V_{ref}$, $I_{KA}=0.1 \sim 20\text{mA}$, $f \leq 1\text{KHz}$

Figure 1. Test Circuit for $V_{KA} = V_{ref}$

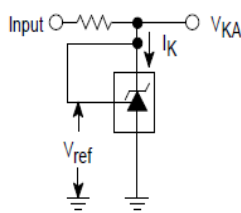

Figure 2. Test Circuit for $V_{KA} > V_{ref}$

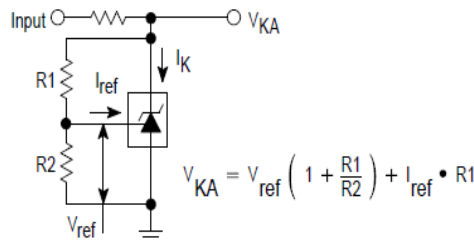
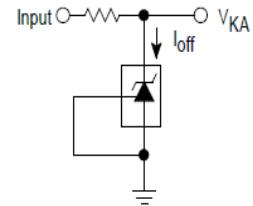

Figure 3. Test Circuit for I_{off}



Note:

1. It is strongly recommended to connect a capacitor (value more than $0.1\mu\text{F}$) at the output pin to smooth the output. The capacitor should be placed as close as possible to the output pin, with the shortest path to GND.

CHARACTERISTIC CURVE

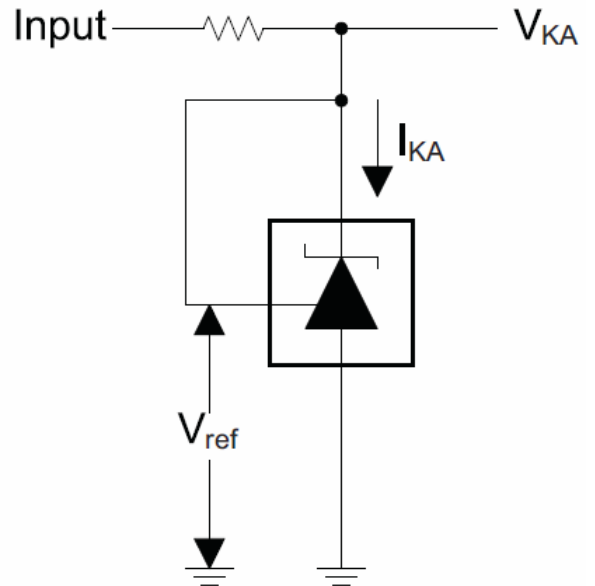
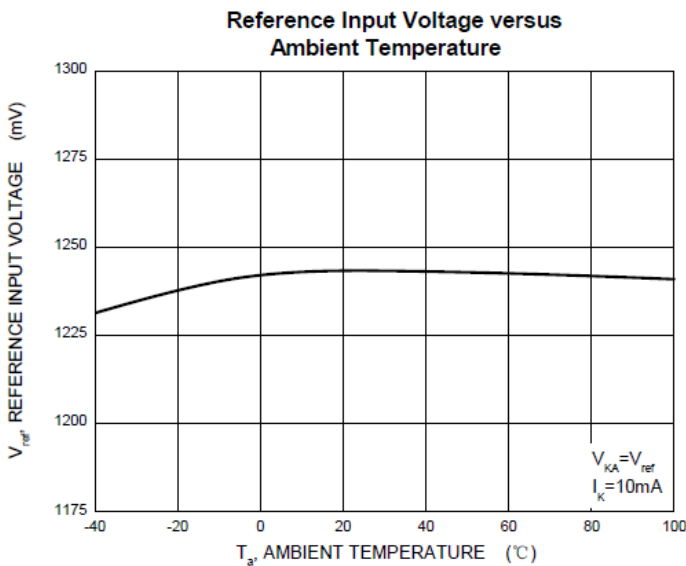
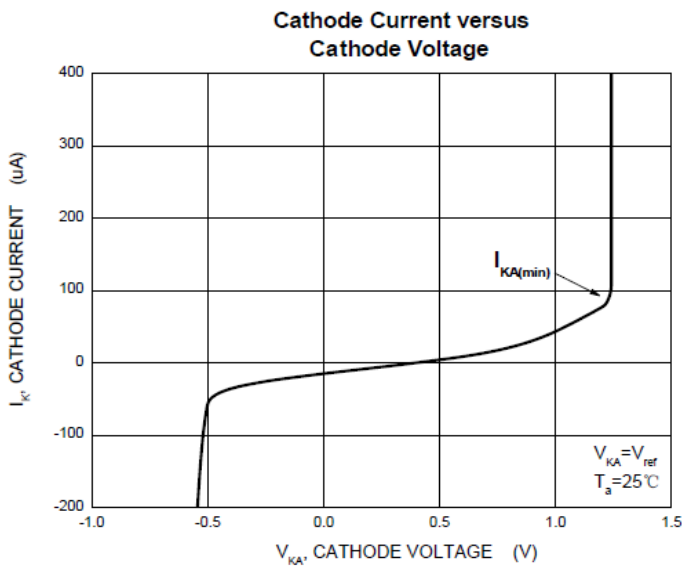
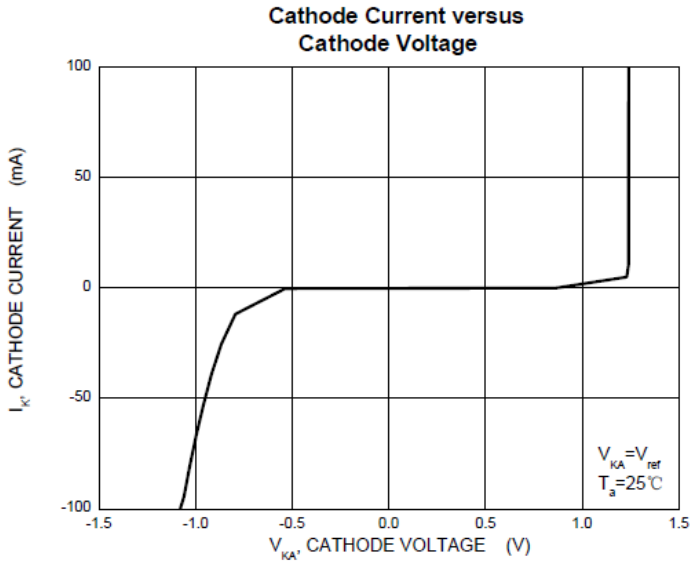

Test Circuit for $V_{KA} = V_{ref}$

CHARACTERISTIC CURVE

Change in Reference Input Voltage versus Cathode Voltage

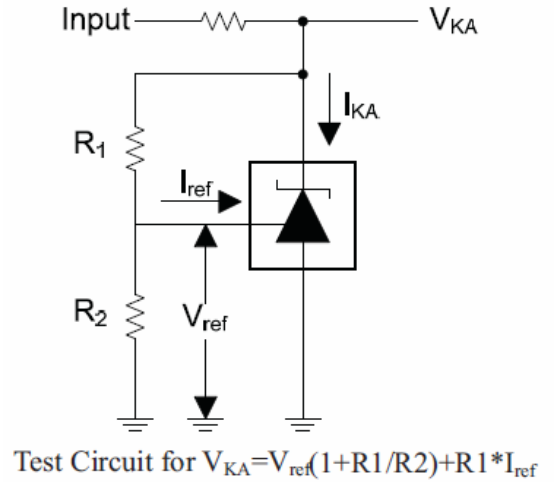
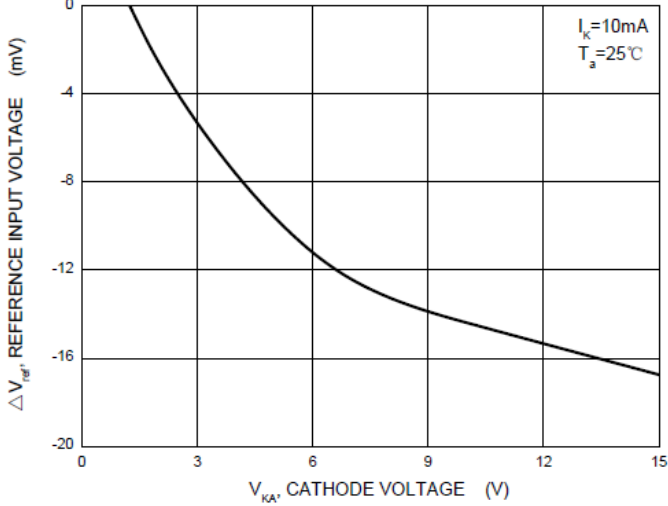

Reference Input Current versus Ambient Temperature

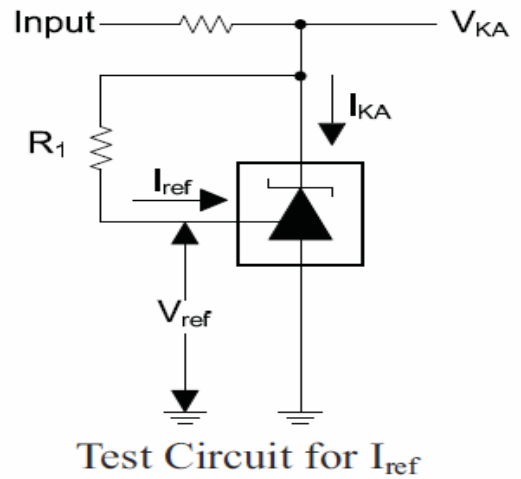
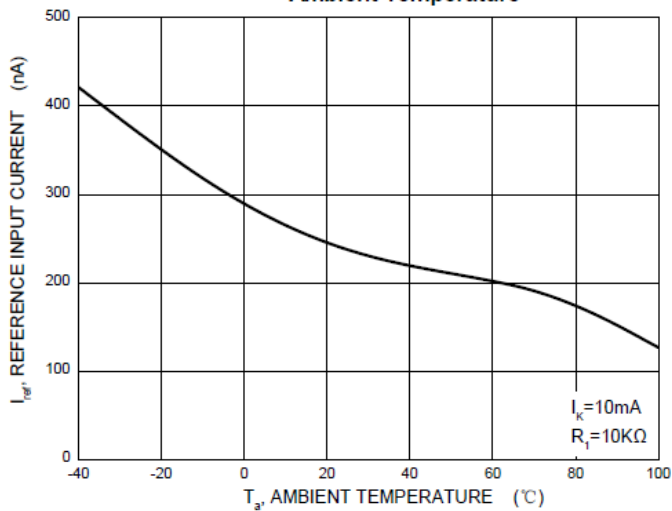

Off-State Cathode Current versus Ambient Temperature

