

RoHS Compliant Product  
A suffix of "-C" specifies halogen & lead-free

## FEATURES

- Fast Switching
- Green Device Available
- ESD : 3KV

SOT-23

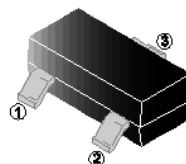

## APPLICATIONS

- POWER Management in Note
- Portable Equipment
- Battery Powered System
- DC/DC Converter
- Load Switch
- LCD Display inverter
- DSC

## MARKING

3415E

01XX

01 : Product Type Marking Code  
XX : Serial Code

## PACKAGE INFORMATION

Package	MPQ	Leader Size
SOT-23	3K	7 inch

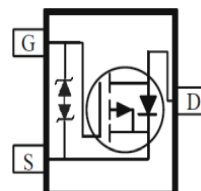

## ORDER INFORMATION

Part Number	Type
SMS04P02-C	Lead (Pb)-free and Halogen-free

## ABSOLUTE MAXIMUM RATINGS ( $T_A=25^\circ\text{C}$ unless otherwise specified)

Parameter	Symbol	Rating	Unit
Drain-Source Voltage	$V_{DS}$	-20	V
Gate-Source Voltage	$V_{GS}$	$\pm 8$	V
Continuous Drain Current	$I_D$	-4	A
Pulsed Drain Current <sup>1</sup>	$I_{DM}$	-16	A
Power Dissipation	$P_D$	0.89	W
Operating Junction & Storage Temperature	$T_J, T_{STG}$	-55~150	$^\circ\text{C}$
<b>Thermal Resistance Ratings</b>			
Thermal Resistance Junction-ambient	$R_{\theta JA}$	140	$^\circ\text{C/W}$

**ELECTRICAL CHARACTERISTICS** ( $T_J=25^\circ\text{C}$  unless otherwise specified)

Parameter	Symbol	Min.	Typ.	Max.	Unit	Test Conditions
Drain-Source Breakdown Voltage	$BV_{DSS}$	-20	-	-	V	$V_{GS}=0V, I_D=-250\mu A$
Gate-Threshold Voltage	$V_{GS(th)}$	-0.3	-	-1	V	$V_{DS}=V_{GS}, I_D=-250\mu A$
Gate-Source Leakage Current	$I_{GSS}$	-	-	$\pm 10$	$\mu A$	$V_{DS}=0V, V_{GS}=\pm 8V$
Drain-Source Leakage Current	$I_{DSS}$	-	-	-1	$\mu A$	$V_{GS}=0V, V_{DS}=-20V$
Static Drain-Source On-Resistance	$R_{DS(ON)}$	-	-	55	m $\Omega$	$V_{GS}=-4.5V, I_D=-4A$
		-	-	63		$V_{GS}=-2.5V, I_D=-4A$
		-	-	73		$V_{GS}=-1.8V, I_D=-2A$
		-	-	110		$V_{GS}=-1.5V, I_D=-1A$
Forward Transconductance	$g_{fs}$	-	22	-	S	$V_{DS}=-5V, I_D=-4A$
Total Gate Charge	$Q_g$	-	11.1	-	nC	$V_{GS}=-4.5V$ $V_{DS}=-10V$ $I_D=-4A$
Gate-Source Charge	$Q_{gs}$	-	3.1	-		
Gate-Drain Charge	$Q_{gd}$	-	2.4	-		
Turn-on Delay Time	$T_{d(on)}$	-	6	-	nS	$V_{GS}=-4.5V$ $V_{DD}=-10V$ $I_D=-1A$ $R_G=2.5\Omega$
Rise Time	$T_r$	-	5	-		
Turn-off Delay Time	$T_{d(off)}$	-	16	-		
Fall Time	$T_f$	-	3	-		
Input Capacitance	$C_{iss}$	-	989	-	pF	$V_{GS}=0V$ $V_{DS}=-10V$ $f=1MHz$
Output Capacitance	$C_{oss}$	-	167	-		
Reverse Transfer Capacitance	$C_{rss}$	-	75.5	-		
<b>Source-Drain Diode</b>						
Continuous Current	$I_S$	-	-	-2.2	A	$V_G=V_D=0V, \text{Force Current}$
Diode Forward Voltage	$V_{SD}$	-	-	-1	V	$V_{GS}=0V, I_S=-1A$

Notes:

1. Repetitive Rating : Pulsed width limited by maximum junction temperature.
2. The data tested by pulsed , pulse width  $\leq 300\mu s$  , duty cycle  $\leq 2\%$ .

**CHARACTERISTIC CURVES**

FIG. 1-Output Characteristics

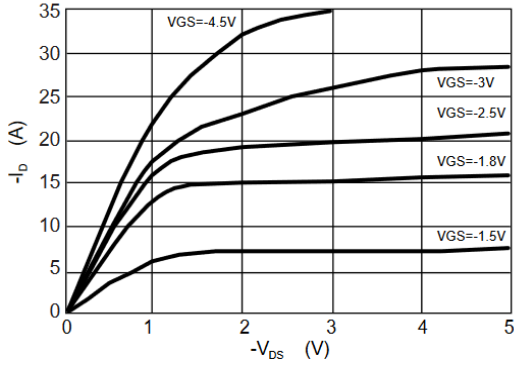

FIG. 2-Transfer Characteristics

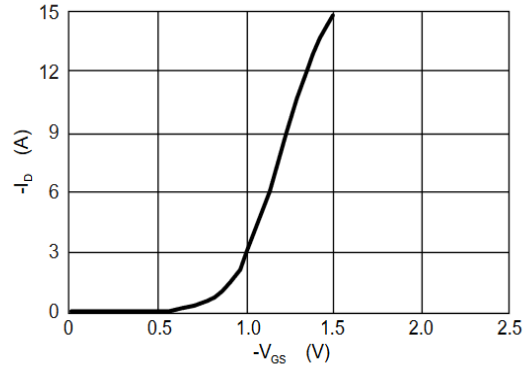

FIG. 3- $R_{DS(ON)}$  vs  $I_D$

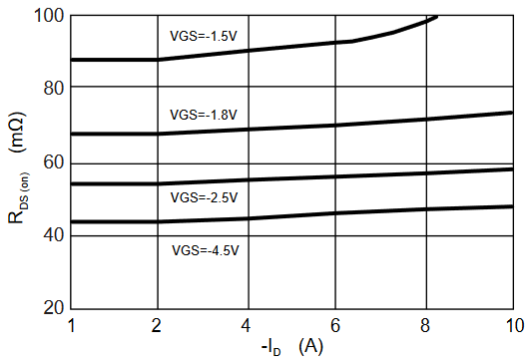

FIG. 4-Normalized  $R_{DS(ON)}$  vs  $T_J$

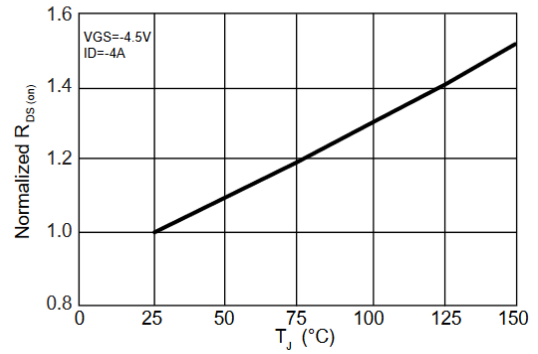

FIG. 5- $I_S$  vs  $V_{SD}$

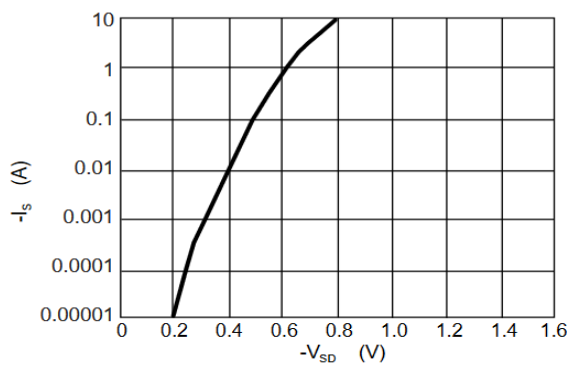

FIG. 6- $I_D$  vs  $T_A$

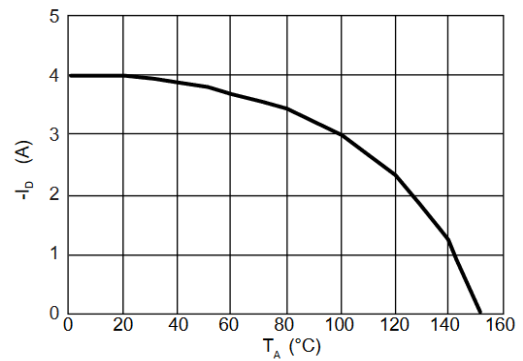

FIG. 7-Switching Time Waveform

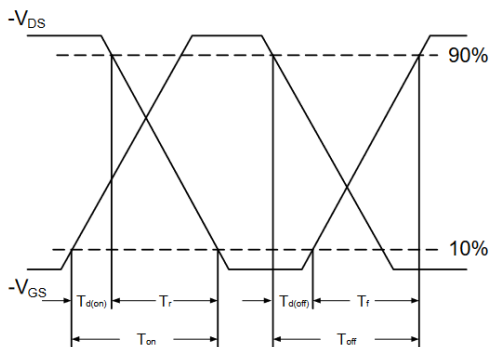
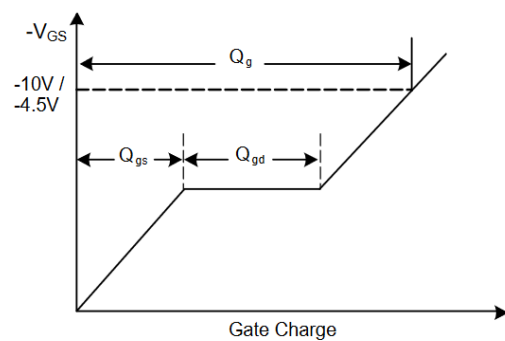
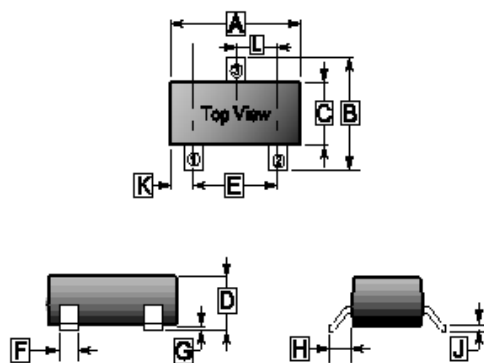

FIG. 8-Gate Charge Waveform



**PACKAGE OUTLINE DIMENSIONS**

**SOT-23**



REF.	Millimeter	
	Min.	Max.
A	2.65	3.10
B	2.10	3.00
C	1.10	1.80
D	0.89	1.45
E	1.70	2.30
F	0.28	0.55
G	0	0.18
H	0.55 REF.	
J	0.05	0.26
K	0.60 REF.	
L	0.95 TYP.	

**MOUNTING PAD LAYOUT**

**SOT-23**

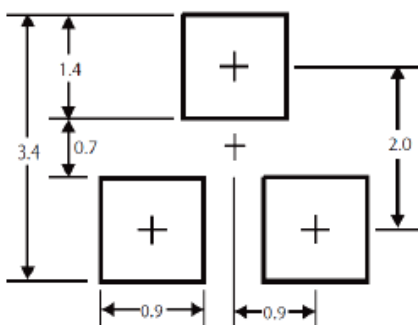

\*Dimensions in millimeters